

General Description

The DM9000 is a fully integrated and cost-effective single chip Fast Ethernet MAC controller with a general processor interface, a 10/100M PHY and 4K Dword SRAM. It is designed with the low power and high performance process that support 3.3V with 5V tolerance.

The DM9000 also provides a MII interface to connect HPNA device or other support MII interface transceiver. The DM9000 support 8-bit, 16-bit and 32-bit uP interface to internal memory accesses for

different processors. The PHY of the DM9000 can interface to the UTP3,4,5 in 10Base-T and UTP5 in 100Base-TX. It is fully compliance with the IEEE 802.3u Spec. Its auto-negotiation function will automatically configure the DM9000 to take the maximum advantage of its abilities. The DM9000 is also support IEEE 802.3x full-duplex flow control. This programming of the DM9000 is very simple, so user can port the software drivers to any system easily.

Block Diagram

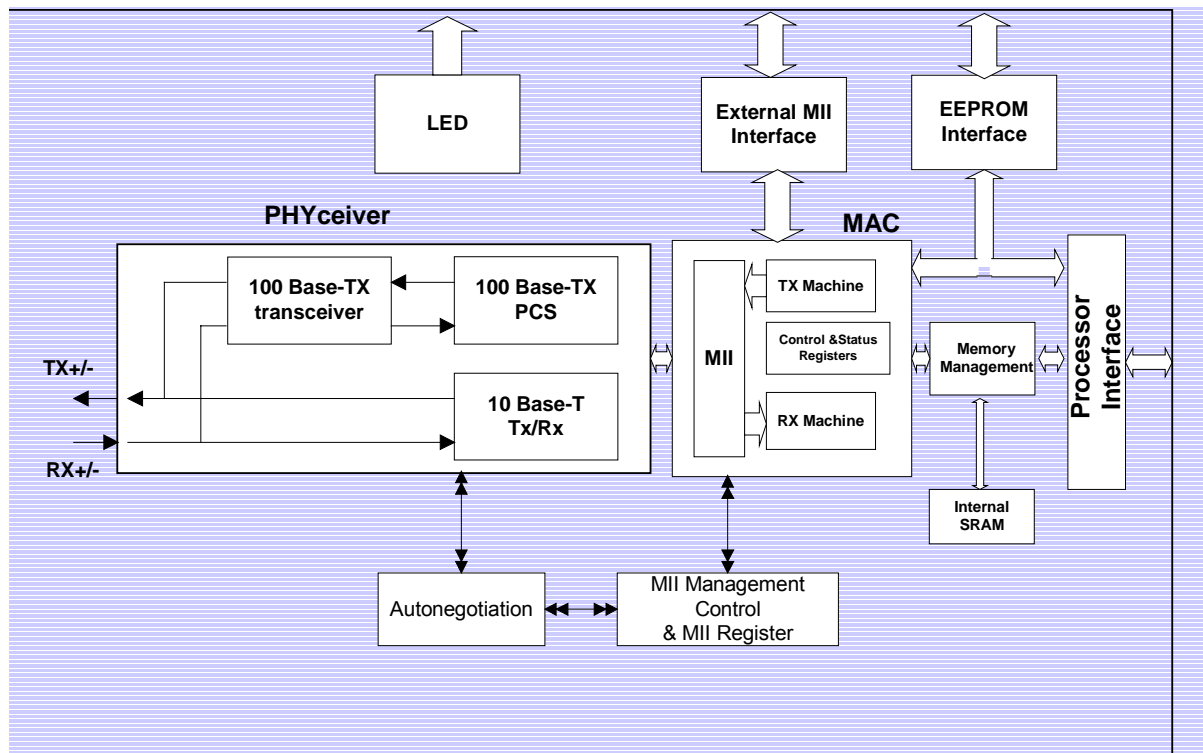

Features

- Supports ISA/uP interface: byte/word/dword of I/O command to internal memory data operation
- Integrated 10/100M transceiver
- Supports MII and reverse MII interface
- Supports Back Pressure Mode for half-duplex mode flow control
- IEEE802.3x flow control for full-duplex mode
- Supports wakeup frame, link status change and Magic packet events for remote wake-up
- Integrated 4K dword SRAM
- Supports automatically load vendor ID and product ID from EEPROM
- Supports 4 GPIO pins
- Optional EEPROM configuration
- Very Low Power consumption mode:
 - Power Reduced mode(cable detection)
 - Power Down mode
 - Selectable TX drivers for 1:1 or 1.25:1 transformers for additional power reduction.
- Compatible with 3.3V and 5.0V tolerant I/O
- 100-pin LQFP

Pin Configuration I (with MII interface)

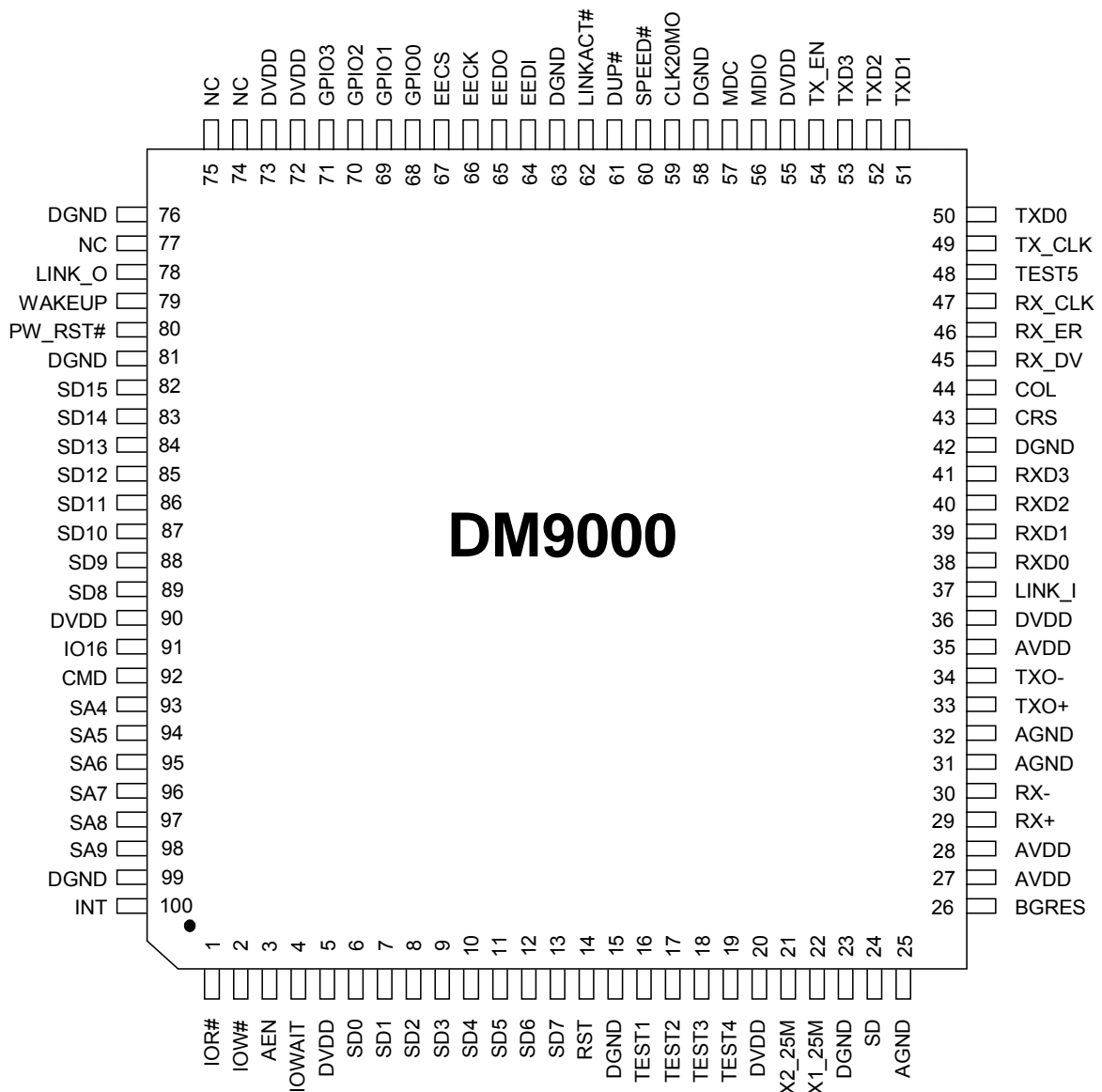



Pin Configuration II (with 32-bit Data Bus)

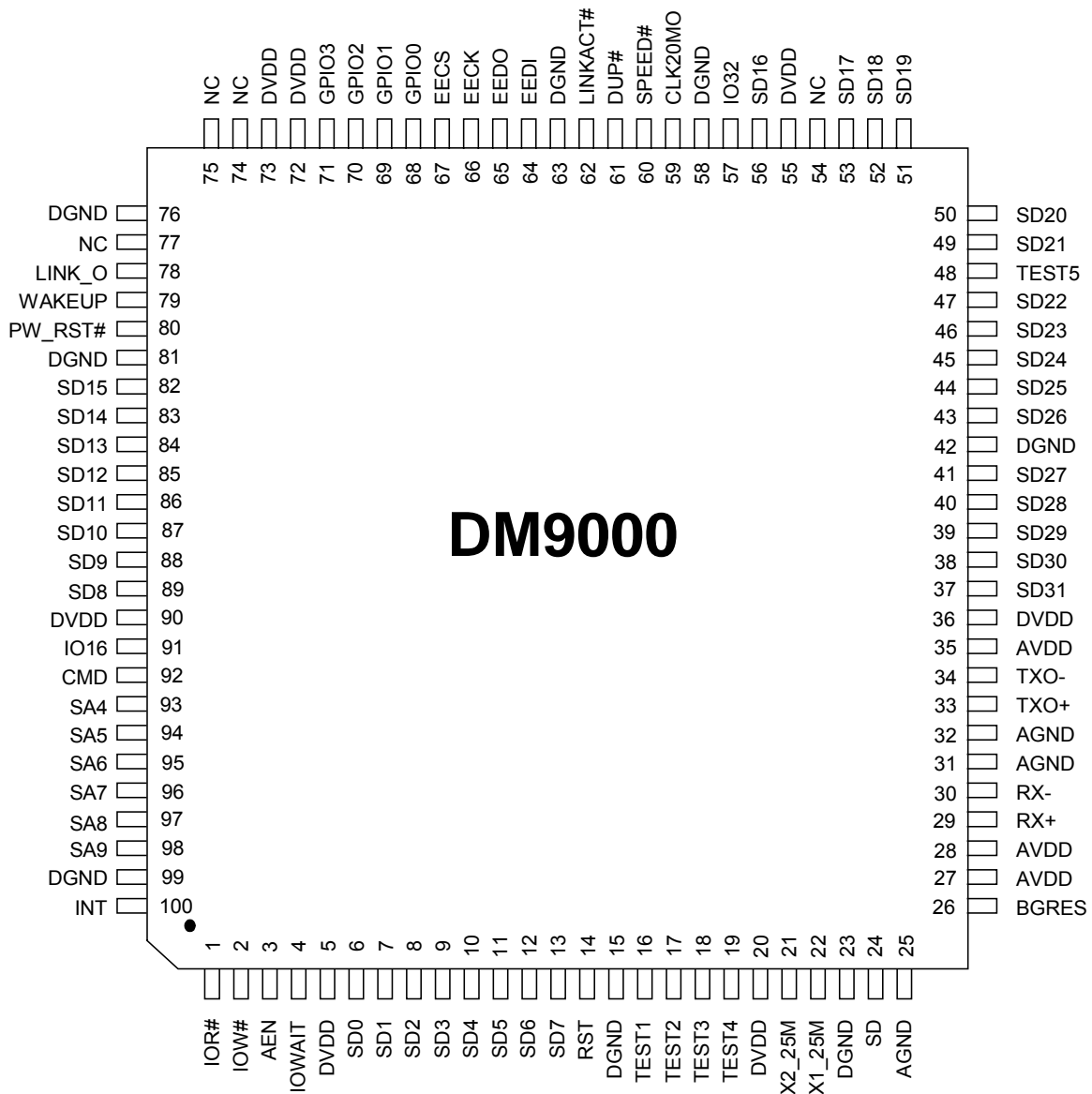



Pin Description

Pin No.	Pin Name	Type	Description
MII Interface			
37	LINK_I	I	External MII device link status.
41,40,39,38	RXD[3:0]	I	External MII Receive Data
43	CRS	I	External MII Carrier Sense
44	COL	I	External MII Collision Detect
45	RX_DV	I	External MII Receive Data Valid
46	RX_ER	I	External MII Receive Error
47	RX_CLK	I	External MII Receive Clock
49	TX_CLK	I	External MII Transmit Clock
53,52,51,50	TXD[3:0]	I/O	External MII Transmit Data TXD[2:0] also used as the strap pins of IO base address when the DM9000 is operated in ISA mode. The IO base = (strap pin value of TXD[2:0]) * 10H + 300H
54	TX_EN	O	External MII Transmit Enable
56	MDIO	I/O	MII Serial Management Data
57	MDC	I/O	MII Serial Management Data Clock This pin is also used as the strap pin of the polarity of the INT pin. When the MDC pin is pull-high, the INT pin low active; otherwise the INT pin is high active.
Processor interface			
1	IOR#	I	Processor Read command. This pin is low active at default, its polarity can be modified by EEPROM setting. See the EEPROM content description for detail.
2	IOW#	I	Processor Write command. This pin is low active at default, its polarity can be modified by EEPROM setting. See the EEPROM content description for detail.
3	AEN	I	Address enable used for ISA mode or chip select for general processor mode. In general processor mode, the polarity of this pin can be modified by EEPROM setting. See the EEPROM content description for detail.
4	IOWAIT	O	Processor command ready When a command is issued before last command completed, the IOWAIT will be pulled to low to indicate the current command is waited.
14	RST	I	Hardware reset command, high active to reset the DM9000.
6,7,8,9,10,11,12,13,89,88,87,86,85,84,83,82	SD0~15	I/O	Processor data bus bit 0~15

Pin Description (Continued)

93,94,95, 96,97,98	SA4~9	I	address bus 4~9 for ISA mode															
92	CMD	I	Command type: When high, the access of this command cycle is DATA port. When low, the access of this command cycle is ADDRESS port.															
91	IO16	O	word command indication When the access of internal memory is word or dword width, this pin will be asserted. This pin is low active at default, its polarity can be modified by EEPROM setting. See the EEPROM content description for detail.															
100	INT	O	interrupt request This pin is high active at default, its polarity can be modified by EEPROM setting or strap pin MDC. See the EEPROM content description for detail.															
56,53,52, 51,50,49, 47,46,45, 44,43,41, 40,39,38 37	SD16~31 (in double word mode)	I/O	Processor data bus bit 16~31 These pins are used as data bus bits 16~31 when the DM9000 is set to double word mode (the straps pin EEDO is pull-high and WAKEUP is not pull-high).															
57	IO32 (in double word mode)	O	Double word command indication This pins is used as the Double word command indication when the DM9000 is set to double data word mode and when the access of internal memory is double word width, this pin will be asserted. This pin is low active at default, its polarity can be modified by EEPROM setting. See the EEPROM content description for detail.															
EEPROM Interface																		
64	EEDI	I	Data from EEPROM															
65	EEDO	I/O	Data to EEPROM This pin is also as a strap pin. Combine with strap pin WOL, it can set the data width of the internal memory access. The decoder table is the following, where the logic 1 means the strap pin is pull-high. <table border="1" style="margin-left: 20px;"> <thead> <tr> <th>WAKEUP</th> <th>EEDO</th> <th>data width</th> </tr> </thead> <tbody> <tr> <td>0</td> <td>0</td> <td>word</td> </tr> <tr> <td>0</td> <td>1</td> <td>double word</td> </tr> <tr> <td>1</td> <td>0</td> <td>byte</td> </tr> <tr> <td>1</td> <td>1</td> <td>reserved</td> </tr> </tbody> </table>	WAKEUP	EEDO	data width	0	0	word	0	1	double word	1	0	byte	1	1	reserved
WAKEUP	EEDO	data width																
0	0	word																
0	1	double word																
1	0	byte																
1	1	reserved																
66	EECK	O	Clock to EEPROM															
67	EECS	I/O	Chip Select to EEPROM This pin is also used as a strap pin to define the LED modes. When it is pull-high, the LED mode is the mode 1; Otherwise it is mode 0.															
Clock Interface																		
21	X2_25M	O	Crystal 25MHz Out															
22	X1_25M	I	Crystal 25MHz In															



59	CLK20MO	O	20Mhz clock output It is used as the clock signal for the external MII device's clock is 20Mhz.
LED Interface			
60	SPEED100#	O	Speed LED It is low output to indicate that the internal PHY is operated in 100M speed, or it is floating for the 10M mode of the internal PHY.
61	DUP#	O	Full-duplex LED In LED mode 1, It is low output to indicate that the internal PHY is operated in full-duplex mode, or it is floating for the half-duplex mode of the internal PHY. In LED mode 0, It is low output to indicate that the internal PHY is operated in 10M mode, or it is floating for the 100M mode of the internal PHY.
62	LINK&ACT#	O	Link LED In LED mode 1, it is the combined LED of link and carrier sense signal of the internal PHY. In LED mode 0, it is the LED of the carrier sense signal of the internal PHY only.
10/100 PHY/Fiber			
24	SD	I	Fiber-optic signal detect PECL signal which indicates whether or not the fiber-optic receives pair is receiving valid levels.
25	AGND		Bandgap ground.
26	BGRES	I/O	Bandgap pin.
27	AVDD		Bandgap and guard ring power
28	AVDD		RX power
29	RX+	I	TP RX input
30	RX-	I	TP RX input
31	AGND		RX ground
32	AGND		TX ground
33	TXO+	O	TP TX output
34	TXO-	O	TP TX output
35	AVDD		TX power
Miscellaneous			
16,17,18,19	TEST1~TEST4	I	Operation Mode Test1,2,3,4=(1,1,0,0) : the processor interface is ISA compatible. Test1,2,3,4=(1,1,0,1) : the processor interface is for general processor .
48	TEST5	I	It must be ground.
68,69,70,71	GPIO0~3	I/O	General I/O ports Registers GPCR and GPR can program these pins. The GPIO0 is output mode with output data high at default to power down internal PHY and other external MII device. GPIO1~3 default are input ports.



DM9000

ISA to Ethernet MAC Controller with Integrated 10/100 PHY

78	LINK_O	O	Cable link status output. Active High. This pin is also used as a strap pin to define the MII interface is reversed MII interface (pull-high) or normal MII interface (not pull-high).
79	WAKEUP	O	Issue a wake-up signal when wake-up event happens.
80	PW_RST#	I	Hardware Reset Active low signal to initiate the DM9000.
74,75,77	NC		Not connect
Power			
5,20,36, 55,72,90, 73	DVDD		Digital VCC
15,23,42, 58,63,81, 99,76	DGND		Digital GND

Vendor Control and Status Register set

The DM9000 implements several control and status registers, which can be accessed by the host. These CSRs

are byte aligned. All CSRs are set to their default values by hardware or software reset unless otherwise specified.

Register	Description	Offset	Default value after reset
NCR	Network Control Register	00H	00H
NSR	Network Status Register	01H	00H
TCR	TX Control Register	02H	00H
TSR I	TX Status Register I	03H	00H
TSR II	TX Status Register II	04H	00H
RCR	RX Control Register	05H	00H
RSR	RX Status Register	06H	00H
ROCR	Receive Overflow Counter Register	07H	00H
BPTR	Back Pressure Threshold Register	08H	37H
FCTR	Flow Control Threshold Register	09H	38H
FCR	RX Flow Control Register	0AH	00H
EPCR	EEPROM & PHY Control Register	0BH	00H
EPAR	EEPROM & PHY Address Register	0CH	40H
EPDRL	EEPROM & PHY Low Byte Data Register	0DH	Unknown
EPDRH	EEPROM & PHY High Byte Data Register	0EH	Unknown
WCR	Wake Up Control Register	0FH	00H
PAR	Physical Address Register	10H-15H	Determined by EEPROM
MAR	Multicast Address Register	16H-1DH	Unknown
GPCR	General Purpose Control Register	1EH	01H
GPR	General Purpose Register	1FH	Unknown
TRPAL	TX SRAM read pointer address low byte	22H	00H
TRPAH	TX SRAM read pointer address high byte	23H	00H
RWPAL	RX SRAM write pointer address low byte	24H	04H
RWPAH	RX SRAM write pointer address high byte	25H	0CH
VID	Vendor ID	28H-29H	0A46H
PID	Product ID	2AH-2BH	9000H
CHIPR	CHIP revision	2CH	00H
SMCR	Special Mode Control Register	2FH	00H
MRCMDX	Memory data read command without address increment Register	F0H	Unknown
MRCMD	Memory data read command with address increment Register	F2H	Unknown
MRRL	Memory data read_address Register low byte	F4H	00H
MRRH	Memory data read_address Register high byte	F5H	00H
MWCMDX	Memory data write command without address increment Register	F6H	Unknown
MWCMD	Memory data write command with address increment Register	F8H	Unknown
MWRL	Memory data write_address Register low byte	FAH	00H



DM9000

ISA to Ethernet MAC Controller with Integrated 10/100 PHY

MWRH	Memory data write address Register high byte	FBH	00H
TXPLL	TX packet length low byte register	FCH	Unknown
TXPLH	TX packet length high byte register	FDH	Unknown
ISR	Interrupt Status Register	FEH	00H
IMR	Interrupt Mask Register	FFH	00H

Key to Default

In the register description that follows, the default column takes the form:

<Reset Value>, <Access Type>

Where :

<Reset Value>:

- 1 Bit set to logic one
- 0 Bit set to logic zero
- X No default value

<Access Type>:

RO = Read only

RW = Read/Write

R/C = Read and Clear

RW/C1=Read/Write and Cleared by write 1

WO = Write only

Reserved bits are shaded and should be written with 0.

Reserved bits are undefined on read access.



Network Control Register (00H)

Bit	Name	Default	Description
7	EXT_PHY	0,RW	Select external PHY when set. Clear select Internal PHY. This bit will not be affected after a software reset.
6	WAKEEN	0,RW	Wakeup event enable When set, it enables the wakeup function. Clearing this bit will also clear all wakeup event status. This bit will not be affected after a software reset.
5	RESERVED	0,RO	Reserved
4	FCOL	0,RW	Force collision Mode, used for testing.
3	FDX	0,RW	Full-Duplex mode. Read only on Internal PHY mode. R/W on External PHY mode
2:1	LBK	00,RW	Loopback mode Bit 2 1 0 0 normal 0 1 MAC internal loopback 1 0 internal PHY digital loopback 1 1 internal PHY analog loopback
0	RST	0,RW	Software reset and auto clear after 10us

Network Status Register (01H)

Bit	Name	Default	Description
7	SPEED	0,RO	Media speed 0:100Mbps 1:10Mbps, when internal PHY is used. This bit is no meaning when LINKST=0.
6	LINKST	0,RO	Link status 0:link failed 1:link OK, when internal PHY is used.
5	WAKEST	0,RW/C1	Wakeup event status. Clears by read or write 1. This bit will not be affected after a software reset.
4	RESERVED	0,RO	Reserved
3	TX2END	0,RW/C1	TX packet 2 Complete status. Clears by read or write 1. Transmit completion of packet index 2.
2	TX1END	0,RW/C1	TX packet 1 Complete status. Clears by read or write 1. Transmit completion of packet index 1.
1	RXOV	0,RO	RX FIFO Overflow
0	RESERVED	0,RO	Reserved

TX Control Register (02H)

Bit	Name	Default	Description
7	RESERVED	0,RO	Reserved
6	TJDIS	0,RW	Transmit Jabber Disable When set, the transmit Jabber Timer(2048 bytes) is disabled. Otherwise it is enabled.
5	EXCECM	0,RW	Excessive collision mode control : 0:abort this packet when excessive collision count more than 15, 1: still try to transmit this packet
4	PAD_DIS2	0,RW	PAD appends disable for packet index 2.
3	CRC_DIS2	0,RW	CRC appends disable for packet index 2
2	PAD_DIS1	0,RW	PAD appends disable for packet index 1
1	CRC_DIS1	0,RW	CRC appends disable for packet index 1
0	TXREQ	0,RW	TX request. Auto clear after send completely.

TX Status Register I (03H) for packet index I

Bit	Name	Default	Description
7	TJTO	0,RO	Transmit Jabber Time Out It is set to indicate the transmitted frame is truncated due to more than 2048 bytes are transmitted.
6	LC	0,RO	Loss of Carrier It is set to indicate the loss of carrier during the frame transmission. It is not valid in internal loopback mode.
5	NC	0,RO	No Carrier It is set to indicate that no carrier signal during the frame transmission. It is not valid in internal loopback mode.
4	LC	0,RO	Late Collision It is set to indicate a collision occurs after the collision window of 64 bytes.
3	COL	0,RO	Collision packet, collision occurs during transmission.
2	EC	0,RO	Excessive collision It is set to indicate the transmission is aborted due to 16 excessive collisions.
1:0	RESERVED	0,RO	Reserved

TX Status Register II (04H) for packet index I I

Bit	Name	Default	Description
7	TJTO	0,RO	Transmit Jabber Time Out It is set to indicate the transmitted frame is truncated due to more than 2048 bytes are transmitted.
6	LC	0,RO	Loss of Carrier It is set to indicate the loss of carrier during the frame transmission. It is not valid in internal loopback mode.
5	NC	0,RO	No Carrier It is set to indicate that no carrier signal during the frame transmission. It is not valid in internal loopback mode.
4	LC	0,RO	Late Collision It is set to indicate a collision occurs after the collision window of 64 bytes.
3	COL	0,RO	Collision packet, collision occurs during transmission.
2	EC	0,RO	Excessive collision It is set to indicate the transmission is aborted due to 16 excessive collisions.
1:0	RESERVED	0,RO	Reserved

RX Control Register (05H)

Bit	Name	Default	Description
7	RESERVED	0,RO	Reserved
6	WTDIS	0,RW	Watchdog Timer Disable When set, the Watchdog Timer(2048 bytes) is disabled. Otherwise it is enabled.
5	DIS_LONG	0,RW	Discard Long Packet, packet length over 1522byte
4	DIS_CRC	0,RW	Discard CRC Error Packet
3	ALL	0,RW	Pass All Multicast
2	RUNT	0,RW	Pass Runt Packet
1	PRMSC	0,RW	Promiscuous Mode
0	RXEN	0,RW	RX Enable

RX Status Register (06H)

Bit	Name	Default	Description
7	RF	0,RO	Runt Frame It is set to indicate the received frame has the size smaller than 64 bytes.
6	MF	0,RO	Multicast Frame It is set to indicate the received frame has a multicast address.
5	LCS	0,RO	Late Collision Seen It is set to indicate a late collision found during the frame reception.
4	RWTO	0,RO	Receive Watchdog Time-Out It is set to indicate receive more than 2048 bytes.
3	PLE	0,RO	Physical Layer Error It is set to indicate a physical layer error found during the frame reception.
2	AE	0,RO	Alignment Error It is set to indicate the received frame ends with a non-byte boundary.
1	CE	0,RO	CRC Error It is set to indicate the received frame ends with a CRC error.
0	FOE	0,RO	FIFO Overflow Error It is set to indicate a FIFO Overflow error happens during the frame reception.

Receive Overflow Counter Register (07H)

Bit	Name	Default	Description
7	RXFU	0,R/C	Receive Overflow Counter Overflow This bit is set when the ROC has an overflow condition.
6:0	ROC	0,R/C	Receive Overflow Counter This is a statistic counter to indicate the received packet count upon FIFO overflow.

Back Pressure Threshold Register (08H)

Bit	Name	Default	Description																																																																																					
7:4	BPHW	3h, RW	Back Pressure High Water Overflow Threshold. MAC will generate the jam pattern when RX SRAM free space is lower than this threshold value. Default is 3K-byte free space. Please don't exceed SRAM size. (1 unit=1K bytes)																																																																																					
3:0	JPT	7h, RW	Jam Pattern Time. Default is 200us. <table border="0" style="font-family: monospace; border-collapse: collapse;"> <tr> <td style="padding-right: 10px;">bit3</td> <td style="padding-right: 10px;">bit2</td> <td style="padding-right: 10px;">bit1</td> <td style="padding-right: 10px;">bit0</td> <td style="padding-left: 10px;">time</td> </tr> <tr> <td>0</td><td>0</td><td>0</td><td>0</td><td>5us</td> </tr> <tr> <td>0</td><td>0</td><td>0</td><td>1</td><td>10us</td> </tr> <tr> <td>0</td><td>0</td><td>1</td><td>0</td><td>15us</td> </tr> <tr> <td>0</td><td>0</td><td>1</td><td>1</td><td>25us</td> </tr> <tr> <td>0</td><td>1</td><td>0</td><td>0</td><td>50us</td> </tr> <tr> <td>0</td><td>1</td><td>0</td><td>1</td><td>100us</td> </tr> <tr> <td>0</td><td>1</td><td>1</td><td>0</td><td>150us</td> </tr> <tr> <td>0</td><td>1</td><td>1</td><td>1</td><td>200us</td> </tr> <tr> <td>1</td><td>0</td><td>0</td><td>0</td><td>250us</td> </tr> <tr> <td>1</td><td>0</td><td>0</td><td>1</td><td>300us</td> </tr> <tr> <td>1</td><td>0</td><td>1</td><td>0</td><td>350us</td> </tr> <tr> <td>1</td><td>0</td><td>1</td><td>1</td><td>400us</td> </tr> <tr> <td>1</td><td>1</td><td>0</td><td>0</td><td>450us</td> </tr> <tr> <td>1</td><td>1</td><td>0</td><td>1</td><td>500us</td> </tr> <tr> <td>1</td><td>1</td><td>1</td><td>0</td><td>550us</td> </tr> <tr> <td>1</td><td>1</td><td>1</td><td>1</td><td>600us</td> </tr> </table>	bit3	bit2	bit1	bit0	time	0	0	0	0	5us	0	0	0	1	10us	0	0	1	0	15us	0	0	1	1	25us	0	1	0	0	50us	0	1	0	1	100us	0	1	1	0	150us	0	1	1	1	200us	1	0	0	0	250us	1	0	0	1	300us	1	0	1	0	350us	1	0	1	1	400us	1	1	0	0	450us	1	1	0	1	500us	1	1	1	0	550us	1	1	1	1	600us
bit3	bit2	bit1	bit0	time																																																																																				
0	0	0	0	5us																																																																																				
0	0	0	1	10us																																																																																				
0	0	1	0	15us																																																																																				
0	0	1	1	25us																																																																																				
0	1	0	0	50us																																																																																				
0	1	0	1	100us																																																																																				
0	1	1	0	150us																																																																																				
0	1	1	1	200us																																																																																				
1	0	0	0	250us																																																																																				
1	0	0	1	300us																																																																																				
1	0	1	0	350us																																																																																				
1	0	1	1	400us																																																																																				
1	1	0	0	450us																																																																																				
1	1	0	1	500us																																																																																				
1	1	1	0	550us																																																																																				
1	1	1	1	600us																																																																																				

Flow Control Threshold Register (09H)

Bit	Name	Default	Description
7:4	HWOT	3h, RW	RX FIFO High Water Overflow Threshold Send a pause packet with pause_time=FFFFH when the RX RAM free space is less than this value., If this value is zero, its meaning is no free RX SRAM space. Default is 3K-byte free space. Please don't exceed SRAM size. (1 unit=1K bytes)
3:0	LWOT	8h, RW	RX FIFO Low Water Overflow Threshold Send a pause packet with pause_time=0000 when RX SRAM free space is larger than this value. This pause packet is enabled after high water pause packet transmitted. Default SRAM free space is 8K-byte. Please don't exceed SRAM size. (1 unit=1K bytes)

RX/TX Flow Control Register (0AH)

Bit	Name	Default	Description
7	TXP0	0,RW	TX pause packet, Auto clears after pause packet transmission completion. Set to TX pause packet with time = 0000h
6	TXPF	0,RW	TX pause packet, Auto clears after pause packet transmission completion. Set to TX pause packet with time = FFFFH.
5	TXPEN	0,RW	Force TX Pause Packet Enable Enable the pause packet for high/low water threshold control.
4	BKPA	0,RW	Back pressure mode. This mode is for half duplex mode only. Generate a jam pattern when any packet coming and RX SRAM over BPHW.
3	BKPM	0,RW	Back pressure mode. This mode is for half duplex mode only. Generate a jam pattern when a packet's DA match and RX SRAM over BPHW.
2	RXPS	0,R/C	RX pause packet status, latch and read clear
1	RXPCS	0,RO	RX pause packet current status
0	FLCE	0,RW	Flow Control Enable Set to enable the flow control mode(i.e. to disable TX function).

EEPROM & PHY Control Register (0BH)

Bit	Name	Default	Description
7:6	RESERVED	0,RO	Reserved
5	REEP	0,RW	Reload EEPROM. Driver needs to clear it after operation complete.
4	WEP	0,RW	Write EEPROM enable
3	EPOS	0,RW	EEPROM or PHY Operation Select When reset, select EEPROM; when set, select PHY.
2	ERPRR	0,RW	EEPROM Read or PHY Register Read Command. Driver needs to clear it after operation complete.
1	ERPRW	0,RW	EEPROM Write or PHY Register Write Command. Driver needs to clear it after operation complete.
0	ERRE	0,RO	EEPROM Access Status or PHY Access Status When set, it indicates that the EEPROM or PHY access is in progress.



EEPROM & PHY Address Register (0CH)

Bit	Name	Default	Description
7:6	PHY_ADR	01,RW	PHY Address bit 1 and 0, the PHY address bit [4:2] is force to 0. Force to 01 if internal PHY is selected
5:0	EROA	0,RW	EEPROM Word Address or PHY Register Address

EEPROM & PHY Data Register (EE_PHY_L : 0DH EE_PHY_H : 0EH)

Bit	Name	Default	Description
7:0	EE_PHY_L	X,RW	EEPROM or PHY Low Byte Data
7:0	EE_PHY_H	X,RW	EEPROM or PHY High Byte Data

Wake Up Control Register (0FH)

Bit	Name	Type	Description
7:6	RESERVED	0,RO	Reserved
5	LINKEN	0,RW	When set, enable Link Status Change Wake-up Event. This bit will not be affected after a software reset.
4	SAMPLEEN	0,RW	When set, enable Sample Frame Wake-up Event. This bit will not be affected after a software reset.
3	MAGICEN	0,RW	When set, enable Magic Packet Wake-up Event. This bit will not be affected after a software reset.
2	LINKST	0,RO	When set, indicates link change and Link Status Change Event occurred. This bit will not be affected after a software reset.
1	SAMPLEST	0,RO	When set, indicates the sample frame is received and Sample Frame Event occurred. This bit will not be affected after a software reset.
0	MAGICST	0,RO	When set, indicates the Magic Packet is received and Magic packet Event occurred. This bit will not be affected after a software reset.

Physical Address Register (10H~15H)

Bit	Name	Default	Description
7:0	PAB5	X,RW	Physical Address Byte 5 (15H)
7:0	PAB4	X,RW	Physical Address Byte 4 (14H)
7:0	PAB3	X,RW	Physical Address Byte 3 (13H)
7:0	PAB2	X,RW	Physical Address Byte 2 (12H)
7:0	PAB1	X,RW	Physical Address Byte 1 (11H)
7:0	PAB0	X,RW	Physical Address Byte 0 (10H)

Multicast Address Register (16H~1DH)

Bit	Name	Default	Description
7:0	MAB7	X,RW	Multicast Address Byte 7 (1DH)
7:0	MAB6	X,RW	Multicast Address Byte 6 (1CH)
7:0	MAB5	X,RW	Multicast Address Byte 5 (1BH)
7:0	MAB4	X,RW	Multicast Address Byte 4 (1AH)
7:0	MAB3	X,RW	Multicast Address Byte 3 (19H)
7:0	MAB2	X,RW	Multicast Address Byte 2 (18H)
7:0	MAB1	X,RW	Multicast Address Byte 1 (17H)

7:0	MAB0	X,RW	Multicast Address Byte 0 (16H)
-----	------	------	--------------------------------

General purpose control Register (1EH)

Bit	Name	Default	Description
7:4	RESERVED	0,RO	Reserved
3:0	GEP_CNTL	1,RW	General purpose control: Define the input/output direction of General Purpose Register. When a bit is set 1, the direction of correspondent bit of General Purpose Register is output. GPIO0 default is output for POWER_DOWN function. Others default are input.

General purpose Register (1FH)

Bit	Name	Default	Description
7:4	RESERVED	0,RO	Reserved
3:1	GEPIO3-1	0,RW	General purpose : When the correspondent bit of General Purpose Control Register is 1, the value of the bit is output to pin GEPIO3-1. When the correspondent bit of General Purpose Control Register is 0, the value of the bit be read is reflected from correspondent pins of GEPIO3-1. The GEPIOs are mapped to pins GEPIO3 to GEPIO1 respectively.
0	GEPIO0	1,RW	General purpose : When the correspondent bit of General Purpose Control Register is 1, the value of the bit is output to pin GEPIO0. When the correspondent bit of General Purpose Control Register is 0, the value of the bit be read is reflected from pin GEPIO0. GEPIO0 default output 1 to POWER_DOWN internal PHY. Driver need to clear this POWER_DOWN signal by write "0" when it wants PHY active. If other device need, it also can refer this signal. This default value can be programmed by EEPROM. Please refer EEPROM description.

TX SRAM Read Pointer Address Register (22H~23H)

Bit	Name	Default	Description
7:0	TRPAH	00h,RO	TX SRAM read pointer address high byte (23H)
7:0	TRPAL	00h,RO	TX SRAM read pointer address low byte (22H)

RX SRAM Write Pointer Address Register (24H~25H)

Bit	Name	Default	Description
7:0	RWPAH	0Ch,RO	RX SRAM write pointer address high byte (25H)
7:0	RWPAL	04h,RO	RX SRAM write pointer address low byte (24H)

Vendor ID Register (28H~29H)

Bit	Name	Default	Description
7:0	VIDH	0Ah,RO	Vendor ID high byte (29H)
7:0	VIDL	46h,RO	Vendor ID low byte (28H)

Product ID Register (2AH~2BH)

Bit	Name	Default	Description
7:0	PIDH	90h,RO	Product ID high byte (2BH)
7:0	PIDL	00h,RO	Product ID low byte (2AH)

Chip Revision Register (2CH)

Bit	Name	Default	Description
7:0	CHIPR	00h,RO	CHIP revision

Special Mode Control Register (2FH)

Bit	Name	Default	Description
7	SM_EN	0,RW	Special mode enable
6~3	RESERVED	0,RO	Reserved
2	FLC	0,RW	Force late collision
1	FB1	0,RW	Force back 1
0	FB0	0,RW	Force back 0

Memory data read command without address increment Register (F0H)

Bit	Name	Default	Description
7:0	MRCMDX	X,RO	Read data from RX SRAM. This register can be byte, word or dword mode depend on the data width. After the operation, the read pointer is unchanged.

Memory data read command with address increment Register (F2H)

Bit	Name	Default	Description
7:0	MRCMD	X,RO	Read data from RX SRAM. This register can be byte, word or dword mode depend on the data width. After the operation, the read pointer advances to next address according to the operation mode.

Memory data read_address Register (F4H~F5H)

Bit	Name	Default	Description
7:0	MDRAH	00h,R/W	Memory data read_address high byte. It will be set to 0Ch, when IMR bit7 =1.
7:0	MDRAL	00h,R/W	Memory data read_address low byte

Memory data write command without address increment Register (F6H)

Bit	Name	Default	Description
7:0	MWCMDX	X,WO	Write data to TX SRAM. This register can be byte, word or dword mode depend on the data width. After the operation, the pointer is unchanged.

Memory data write command with address increment Register (F8H)

Bit	Name	Default	Description
7:0	MWCMD	X,WO	Write data to TX SRAM. This register can be byte, word or dword mode depend on the data width. After the operation, the pointer advance to next addresses according to the operation mode.

Memory data write_address Register (FAH~FBH)

Bit	Name	Default	Description
7:0	MDRAH	00h,R/W	Memory data write_address high byte.
7:0	MDRAL	00h,R/W	Memory data write_address low byte

TX Packet Length Register (FCH~FDH)

Bit	Name	Default	Description
7:0	TXPLH	X,R/W	TX Packet Length High byte
7:0	TXPLL	X,,R/W	TX Packet Length Low byte

Interrupt Status Register (FEH)

Bit	Name	Default	Description
7	IOMODE	0, RO	0:word mode, 1:byte mode if bit 6 = 0
6	IO_DWM	0, RO	0:non-dword mode, 1: dword mode
5~4	RESERVED	0,RO	Reserved
3	ROOS	0,RW/C1	Receive Overflow Counter Overflow latch
2	ROS	0,RW/C1	Rx overflow latch
1	PTS	0,RW/C1	Packet transmitted latch
0	PRS	0,RW/C1	Packet received latch

Interrupt Mask Register (FFH)

Bit	Name	Default	Description
7	PAR	0,RW	Enable SRAM read/write pointer automatically return the start address when pointer addresses over SRAM size. Driver needs to set. When driver set this bit, REG_F5 will set to 0Ch automatically.
6~4	RESERVED	0,RO	Reserved
3	ROOM	0,RW	Enable Receive Overflow Counter Overflow latch
2	ROM	0,RW	Enable rx overflow latch
1	PTM	0,RW	Enable packet transmitted latch
0	PRM	0,RW	Enable packet received latch



EEPROM Format

name	Word	offset	description
MAC address	0	0~5	6 byte ethernet address
Auto Load Control	3	6-7	Bit 1:0=01: Update vendor ID and product ID Bit 3:2=01: Accept setting of WORD6[8:0] Bit 5:4=01: Accept setting of WORD6[11:9] Bit 7:6=01: Accept setting of WORD7[3:0] Bit 9:8=01: Accept setting of WORD7[6:4] Bit 11:10=01: Accept setting of WORD7[7] Bit 13:12=01: Accept setting of WORD7[8] Bit 15:14=01: reserved
Vendor ID	4	8-9	2 byte vendor ID (Default: 0A46H)
Product ID	5	10-11	2 byte product ID (Default: 9000H)
uP control	6	12-13	Bit0: uP CS active low when set (default: active high) Bit1: uP/ISA IOR active low when set (default: active low) Bit2: uP/ISA IOW active low when set (default: active low) Bit3: uP/ISA IRQ active low when set (default: active high) Bit4: uP/ISA IRQ is open-collect (default: force output) Bit5: uP/ISA IOWAIT active low when set (default: active low) Bit6: uP/ISA IOWAIT is open-collect (default: force output) Bit7: uP/ISA IO16 active low when set (default: active low) Bit8: uP/ISA IO16 is open-collect (default: force output) Bit11:09: ISA I/O base (default: 300H) 000 : 300H 001 : 310H 010 : 320H 011 : 330H 100 : 340H 101 : 350H 110 : 360H 111 : 370H Bit15:12: reserved
Wake-up mode control	7	14-15	Bit0: The WAKEUP pin active low when set (default: active high) Bit1: The WAKEUP pin is pulse mode when set (default: level mode) Bit2: magic wakeup event enabled when set. (default: no) Bit3: link_change wakeup event enabled when set (default: no) Bit6:4: reserved Bit7: LED mode 1 (default: 0) Bit8: internal PHY is enabled after power-on (default: no) Bit15:9: reserved
RESERVED	8	16-17	
RESERVED	9	18-19	
RESERVED	10	20-21	
RESERVED	11	22-23	



MII Register Description

AD D	Name	15	14	13	12	11	10	9	8	7	6	5	4	3	2	1	0
00	CONTROL	Reset	Loop back	Speed select	Auto-N Enable	Power Down	Isolate	Restart Auto-N	Full Duplex	Coll. Test	Reserved						
01	STATUS	T4 Cap.	TX FDX Cap.	TX HDX Cap.	10 FDX Cap.	10 HDX Cap.	Reserved				Pream. Supr.	Auto-N Compl.	Remote Fault	Auto-N Cap.	Link Status	Jabber Detect	Extd Cap.
02	PHYID1	0	0	0	0	0	0	0	1	1	0	0	0	0	0	0	0
03	PHYID2	1	0	1	1	1	0	Model No.				Version No.					
04	Auto-Neg. Advertise	Next Page	FLP Rcv Ack	Remote Fault	Reserved		FC Adv	T4 Adv	TX FDX Adv	TX HDX Adv	10 FDX Adv	10 HDX Adv	Advertised Protocol Selector Field				
05	Link Part. Ability	LP Next Page	LP Ack	LP RF	Reserved		LP FC	LP T4	LP TX FDX	LP TX HDX	LP 10 FDX	LP 10 HDX	Link Partner Protocol Selector Field				
06	Auto-Neg. Expansion	Reserved										Pardet Fault	LP Next Pg Able	Next Pg Able	New Pg Rcv	LP AutoN Cap.	
16	Specified Config.	BP 4B5B	BP SCR	BP ALIGN	BP_AD POK	Rsvd	TX	Rsvd	Rsvd	Force 100LNK	Reserved		RPDCTR -EN	Reset St. Mch	Pream. Supr.	Sleep mode	Remote LoopOut
17	Specified Conf/Stat	100 FDX	100 HDX	10 FDX	10 HDX	Reserved			PHY ADDR [4:0]				Auto-N. Monitor Bit [3:0]				
18	10T Conf/Stat	Rsvd	LP Enable	HBE Enable	SQUE Enable	JAB Enable	10T Serial	Reserved									Polarity Reverse

Key to Default

In the register description that follows, the default column takes the form:

<Reset Value>, <Access Type> / <Attribute(s)>

Where :

<Reset Value>:

1 Bit set to logic one

0 Bit set to logic zero

X No default value

(PIN#) Value latched in from pin # at reset

<Access Type>:

RO = Read only

RW = Read/Write

<Attribute (s)>:

SC = Self clearing

P = Value permanently set

LL = Latching low

LH = Latching high

Basic Mode Control Register (BMCR) - 00

Bit	Bit Name	Default	Description
0.15	Reset	0, RW/SC	Reset: 1=Software reset 0=Normal operation This bit sets the status and controls the PHY registers to their default states. This bit, which is self-clearing, will keep returning a value of one until the reset process is completed
0.14	Loopback	0, RW	Loopback: Loop-back control register 1 = Loop-back enabled 0 = Normal operation When in 100Mbps operation mode, setting this bit may cause the descrambler to lose synchronization and produce a 720ms "dead time" before any valid data appear at the MII receive outputs
0.13	Speed selection	1, RW	Speed select: 1 = 100Mbps 0 = 10Mbps Link speed may be selected either by this bit or by auto-negotiation. When auto-negotiation is enabled and bit 12 is set, this bit will return auto-negotiation selected media type.
0.12	Auto-negotiation enable	1, RW	Auto-negotiation enable: 1 = Auto-negotiation is enabled, bit 8 and 13 will be in auto-negotiation status
0.11	Power down	0, RW	Power Down: While in the power-down state, the PHY should respond to management transactions. During the transition to power-down state and while in the power-down state, the PHY should not generate spurious signals on the MII. 1=Power down 0=Normal operation
0.10	Isolate	0,RW	Isolate: 1 = Isolates the PHY from the MII with the exception of the serial management. (When this bit is asserted, the PHY does not respond to the TXD[0:3], TX_EN, and TX_ER inputs, and it shall present a high impedance on its TX_CLK, RX_CLK, RX_DV, RX_ER, RX[0:3], COL and CRS outputs. When PHY is isolated from the MII it shall respond to the management transactions) 0 = Normal operation
0.9	Restart auto-negotiation	0,RW/SC	Restart auto-negotiation: 1 = Restart auto-negotiation. Re-initiates the auto-negotiation process. When auto-negotiation is disabled (bit 12 of this register cleared), this bit has no function and it should be cleared. This bit is self-clearing and it will keep returning a value of 1 until auto-negotiation is initiated by the PHY. The operation of the auto-negotiation process will not be affected by the management entity that clears this bit 0 = Normal operation



0.8	Duplex mode	1,RW	Duplex mode: 1 = Full duplex operation. Duplex selection is allowed when Auto-negotiation is disabled (bit 12 of this register is cleared). With auto-negotiation enabled, this bit reflects the duplex capability selected by auto-negotiation 0 = Normal operation
0.7	Collision test	0,RW	Collision test: 1 = Collision test enabled. When set, this bit will cause the COL signal to be asserted in response to the assertion of TX_EN 0 = Normal operation
0.6-0.0	RESERVED	0,RO	Reserved: Write as 0, ignore on read

Basic Mode Status Register (BMSR) - 01

Bit	Bit Name	Default	Description
1.15	100BASE-T4	0,RO/P	100BASE-T4 capable: 1 = Able to perform in 100BASE-T4 mode 0 = Not able to perform in 100BASE-T4 mode
1.14	100BASE-TX full duplex	1,RO/P	100BASE-TX full duplex capable: 1 = Able to perform 100BASE-TX in full duplex mode 0 = Not able to perform 100BASE-TX in full duplex mode
1.13	100BASE-TX half duplex	1,RO/P	100BASE-TX half duplex capable: 1 = Able to perform 100BASE-TX in half duplex mode 0 = Not able to perform 100BASE-TX in half duplex mode
1.12	10BASE-T full duplex	1,RO/P	10BASE-T full duplex capable: 1 = Able to perform 10BASE-T in full duplex mode 0 = Not able to perform 10BASE-TX in full duplex mode
1.11	10BASE-T half duplex	1,RO/P	10BASE-T half duplex capable: 1 = Able to perform 10BASE-T in half duplex mode 0 = Not able to perform 10BASE-T in half duplex mode
1.10-1.7	RESERVED	0,RO	Reserved: Write as 0, ignore on read
1.6	MF preamble suppression	0,RO	MF preamble suppression: 1 = PHY will accept management frames with preamble suppressed 0 = PHY will not accept management frames with preamble suppressed
1.5	Auto-negotiation Complete	0,RO	Auto-negotiation complete: 1 = Auto-negotiation process completed 0 = Auto-negotiation process not completed
1.4	Remote fault	0, RO/LH	Remote fault: 1 = Remote fault condition detected (cleared on read or by a chip reset). Fault criteria and detection method is PHY implementation specific. This bit will set after the RF bit in the ANLPAR (bit 13, register address 05) is set 0 = No remote fault condition detected
1.3	Auto-negotiation Ability	1,RO/P	Auto configuration ability: 1 = Able to perform auto-negotiation 0 = Not able to perform auto-negotiation
1.2	Link status	0,RO/LL	Link status: 1 = Valid link is established (for either 10Mbps or 100Mbps)



			operation) 0 = Link is not established The link status bit is implemented with a latching function, so that the occurrence of a link failure condition causes the link status bit to be cleared and remain cleared until it is read via the management interface
1.1	Jabber detect	0, RO/LH	Jabber detect: 1 = Jabber condition detected 0 = No jabber This bit is implemented with a latching function. Jabber conditions will set this bit unless it is cleared by a read to this register through a management interface or a PHY reset. This bit works only in 10Mbps mode
1.0	Extended capability	1,RO/P	Extended capability: 1 = Extended register capable 0 = Basic register capable only

PHY ID Identifier Register #1 (PHYID1) - 02

The PHY Identifier Registers #1 and #2 work together in a single identifier of the DM9000. The Identifier consists of a concatenation of the Organizationally Unique Identifier (OUI), a vendor's model number, and a model revision number. DAVICOM Semiconductor's IEEE assigned OUI is 00606E.

Bit	Bit Name	Default	Description
2.15-2.0	OUI_MSB	<0181h>	OUI most significant bits: This register stores bit 3 to 18 of the OUI (00606E) to bit 15 to 0 of this register respectively. The most significant two bits of the OUI are ignored (the IEEE standard refers to these as bit 1 and 2)

PHY Identifier Register #2 (PHYID2) - 03

Bit	Bit Name	Default	Description
3.15-3.10	OUI_LSB	<101110>, RO/P	OUI least significant bits: Bit 19 to 24 of the OUI (00606E) are mapped to bit 15 to 10 of this register respectively
3.9-3.4	VNDR_MDL	<001100>, RO/P	Vendor model number: Six bits of vendor model number mapped to bit 9 to 4 (most significant bit to bit 9)
3.3-3.0	MDL_REV	<0000>, RO/P	Model revision number: Four bits of vendor model revision number mapped to bit 3 to 0 (most significant bit to bit 3)

Auto-negotiation Advertisement Register(ANAR) - 04

This register contains the advertised abilities of this DM9000 device as they will be transmitted to its link partner during Auto-negotiation.

Bit	Bit Name	Default	Description
4.15	NP	0,RO/P	Next page indication: 0 = No next page available 1 = Next page available The PHY has no next page, so this bit is permanently set to 0
4.14	ACK	0,RO	Acknowledge: 1 = Link partner ability data reception acknowledged 0 = Not acknowledged The PHY's auto-negotiation state machine will automatically control this bit in the outgoing FLP bursts and set it at the appropriate time during the auto-negotiation process. Software should not attempt to write to this bit.
4.13	RF	0, RW	Remote fault: 1 = Local device senses a fault condition 0 = No fault detected
4.12-4.11	RESERVED	X, RW	Reserved: Write as 0, ignore on read
4.10	FCS	0, RW	Flow control support: 1 = Controller chip supports flow control ability 0 = Controller chip doesn't support flow control ability
4.9	T4	0, RO/P	100BASE-T4 support: 1 = 100BASE-T4 is supported by the local device 0 = 100BASE-T4 is not supported The PHY does not support 100BASE-T4 so this bit is permanently set to 0
4.8	TX_FDX	1, RW	100BASE-TX full duplex support: 1 = 100BASE-TX full duplex is supported by the local device 0 = 100BASE-TX full duplex is not supported
4.7	TX_HDX	1, RW	100BASE-TX support: 1 = 100BASE-TX is supported by the local device 0 = 100BASE-TX is not supported
4.6	10_FDX	1, RW	10BASE-T full duplex support: 1 = 10BASE-T full duplex is supported by the local device 0 = 10BASE-T full duplex is not supported
4.5	10_HDX	1, RW	10BASE-T support: 1 = 10BASE-T is supported by the local device 0 = 10BASE-T is not supported
4.4-4.0	Selector	<00001>, RW	Protocol selection bits: These bits contain the binary encoded protocol selector supported by this node. <00001> indicates that this device supports IEEE 802.3 CSMA/CD.



Auto-negotiation Link Partner Ability Register (ANLPAR) – 05

This register contains the advertised abilities of the link partner when received during Auto-negotiation.

Bit	Bit Name	Default	Description
5.15	NP	0, RO	Next page indication: 0 = Link partner, no next page available 1 = Link partner, next page available
5.14	ACK	0, RO	Acknowledge: 1 = Link partner ability data reception acknowledged 0 = Not acknowledged The PHY's auto-negotiation state machine will automatically control this bit from the incoming FLP bursts. Software should not attempt to write to this bit.
5.13	RF	0, RO	Remote Fault: 1 = Remote fault indicated by link partner 0 = No remote fault indicated by link partner
5.12-5.11	RESERVED	X, RO	Reserved: Write as 0, ignore on read
5.10	FCS	0, RW	Flow control support: 1 = Controller chip supports flow control ability by link partner 0 = Controller chip doesn't support flow control ability by link partner
5.9	T4	0, RO	100BASE-T4 support: 1 = 100BASE-T4 is supported by the link partner 0 = 100BASE-T4 is not supported by the link partner
5.8	TX_FDX	0, RO	100BASE-TX full duplex support: 1 = 100BASE-TX full duplex is supported by the link partner 0 = 100BASE-TX full duplex is not supported by the link partner
5.7	TX_HDX	0, RO	100BASE-TX support: 1 = 100BASE-TX half duplex is supported by the link partner 0 = 100BASE-TX half duplex is not supported by the link partner
5.6	10_FDX	0, RO	10BASE-T full duplex support: 1 = 10BASE-T full duplex is supported by the link partner 0 = 10BASE-T full duplex is not supported by the link partner
5.5	10_HDX	0, RO	10BASE-T support: 1 = 10BASE-T half duplex is supported by the link partner 0 = 10BASE-T half duplex is not supported by the link partner
5.4-5.0	Selector	<00000>, RO	Protocol selection bits: Link partner's binary encoded protocol selector

Auto-negotiation Expansion Register (ANER)- 06

6.15-6.5	RESERVED	X, RO	Reserved: Write as 0, ignore on read
6.4	PDF	0, RO/LH	Local device parallel detection fault: PDF = 1 : A fault detected via parallel detection function. PDF = 0 : No fault detected via parallel detection function



6.3	LP_NP_ABLE	0, RO	Link partner next page able: LP_NP_ABLE = 1 : Link partner, next page available LP_NP_ABLE = 0 : Link partner, no next page
6.2	NP_ABLE	0,RO/P	Local device next page able: NP_ABLE = 1 : next page available NP_ABLE = 0 : no next page
6.1	PAGE_RX	0, RO/LH	New page received: A new link code word page received. This bit will be automatically cleared when the register (register 6) is read by management.
6.0	LP_AN_ABLE	0, RO	Link partner auto-negotiation able: A "1" in this bit indicates that the link partner supports Auto-negotiation.

DAVICOM Specified Configuration Register (DSCR) - 16

Bit	Bit Name	Default	Description
16.15	BP_4B5B	0, RW	Bypass 4B5B encoding and 5B4B decoding : 1 = 4B5B encoder and 5B4B decoder function bypassed 0 = Normal 4B5B and 5B4B operation
16.14	BP_SCR	0, RW	Bypass scrambler/descrambler function : 1 = Scrambler and descrambler function bypassed 0 = Normal scrambler and descrambler operation
16.13	BP_ALIGN	0, RW	Bypass symbol alignment function: 1 = Receive functions (descrambler, symbol alignment and symbol decoding functions) bypassed. Transmit functions (symbol encoder and scrambler) bypassed 0 = Normal operation
16.12	BP_ADPOK	0, RW	BYPASS ADPOK : Force signal detector (SD) active. This register is for debug only, not release to customer. 1=Force SD is OK, 0=Normal operation
16.11	RESERVED	0, RO	Reserved : Write as 0, ignore on read.
16.10	TX	1, RO	100BASE-TX: 1 = 100BASE-TX operation 0 = Reserved
16.9	RESERVED	0, RO	Reserved
16.8	RESERVED	0, RO	Reserved: Write as 0, ignore on read.
16.7	F_LINK_100	0, RW	Force good link in 100Mbps: 0 = Normal 100Mbps operation 1 = Force 100Mbps good link status This bit is useful for diagnostic purposes.
16.6	RESERVED	0, RO	Reserved: Write as 0, ignore on read.
16.5	RESERVED	0, RO	Reserved: Write as 0, ignore on read.
16.4	RPDCTR-EN	1, RW	Reduced power down control enable: This bit is used to enable automatic reduced power down. 0 : Disable automatic reduced power down.

			1 : Enable automatic reduced power down.
16.3	SMRST	0, RW	Reset state machine: When writes 1 to this bit, all state machines of PHY will be reset. This bit is self-clear after reset is completed.
16.2	MFPSC	0, RW	MF preamble suppression control: MII frame preamble suppression control bit 1 = MF preamble suppression bit on 0 = MF preamble suppression bit off
16.1	SLEEP	0, RW	Sleep mode: Writing a 1 to this bit will cause PHY entering the Sleep mode and power down all circuit except oscillator and clock generator circuit. When waking up from Sleep mode (write this bit to 0), the configuration will go back to the state before sleep; but the state machine will be reset
16.0	RLOUT	0, RW	Remote loopout control: When this bit is set to 1, the received data will loop out to the transmit channel. This is useful for bit error rate testing

DAVICOM Specified Configuration and Status Register (DSCSR) - 17

Bit	Bit Name	Default	Description
17.15	100FDX	1, RO	100M full duplex operation mode: After auto-negotiation is completed, results will be written to this bit. If this bit is 1, it means the operation 1 mode is a 100M full duplex mode. The software can read bit[15:12] to see which mode is selected after auto-negotiation. This bit is invalid when it is not in the auto-negotiation mode.
17.14	100HDX	1, RO	100M half duplex operation mode: After auto-negotiation is completed, results will be written to this bit. If this bit is 1, it means the operation 1 mode is a 100M half duplex mode. The software can read bit[15:12] to see which mode is selected after auto-negotiation. This bit is invalid when it is not in the auto-negotiation mode.
17.13	10FDX	1, RO	10M full duplex operation mode: After auto-negotiation is completed, results will be written to this bit. If this bit is 1, it means the operation 1 mode is a 10M Full Duplex mode. The software can read bit[15:12] to see which mode is selected after auto-negotiation. This bit is invalid when it is not in the auto-negotiation mode.
17.12	10HDX	1, RO	10M half duplex operation mode: After auto-negotiation is completed, results will be written to this bit. If this bit is 1, it means the operation 1 mode is a 10M half duplex mode. The software can read bit[15:12] to see which mode is selected after auto-negotiation. This bit is invalid when it is not in the auto-negotiation mode.
17.11-17.9	RESERVED	0, RO	Reserved: Write as 0, ignore on read
17.8-17.4	PHYADR[4:0]	(PHYADR), RW	PHY address Bit 4:0: The first PHY address bit transmitted or received is the MSB of the address (bit 4). A station management entity connected to multiple PHY entities must know the appropriate address of each PHY.

17.3-17.0	ANMB[3:0]	0, RO	<p>Auto-negotiation monitor bits: These bits are for debug only. The auto-negotiation status will be written to these bits.</p> <table border="1"> <thead> <tr> <th>B3</th> <th>b2</th> <th>b1</th> <th>b0</th> <th></th> </tr> </thead> <tbody> <tr> <td>0</td> <td>0</td> <td>0</td> <td>0</td> <td>In IDLE state</td> </tr> <tr> <td>0</td> <td>0</td> <td>0</td> <td>1</td> <td>Ability match</td> </tr> <tr> <td>0</td> <td>0</td> <td>1</td> <td>0</td> <td>Acknowledge match</td> </tr> <tr> <td>0</td> <td>0</td> <td>1</td> <td>1</td> <td>Acknowledge match fail</td> </tr> <tr> <td>0</td> <td>1</td> <td>0</td> <td>0</td> <td>Consistency match</td> </tr> <tr> <td>0</td> <td>1</td> <td>0</td> <td>1</td> <td>Consistency match fail</td> </tr> <tr> <td>0</td> <td>1</td> <td>1</td> <td>0</td> <td>Parallel detects signal_link_ready</td> </tr> <tr> <td>0</td> <td>1</td> <td>1</td> <td>1</td> <td>Parallel detects signal_link_ready fail</td> </tr> <tr> <td>1</td> <td>0</td> <td>0</td> <td>0</td> <td>Auto-negotiation completed successfully</td> </tr> </tbody> </table>	B3	b2	b1	b0		0	0	0	0	In IDLE state	0	0	0	1	Ability match	0	0	1	0	Acknowledge match	0	0	1	1	Acknowledge match fail	0	1	0	0	Consistency match	0	1	0	1	Consistency match fail	0	1	1	0	Parallel detects signal_link_ready	0	1	1	1	Parallel detects signal_link_ready fail	1	0	0	0	Auto-negotiation completed successfully
B3	b2	b1	b0																																																		
0	0	0	0	In IDLE state																																																	
0	0	0	1	Ability match																																																	
0	0	1	0	Acknowledge match																																																	
0	0	1	1	Acknowledge match fail																																																	
0	1	0	0	Consistency match																																																	
0	1	0	1	Consistency match fail																																																	
0	1	1	0	Parallel detects signal_link_ready																																																	
0	1	1	1	Parallel detects signal_link_ready fail																																																	
1	0	0	0	Auto-negotiation completed successfully																																																	

10BASE-T Configuration/Status (10BTCSR) - 18

Bit	Bit Name	Default	Description
18.15	RESERVED	0, RO	Reserved: Write as 0, ignore on read
18.14	LP_EN	1, RW	Link pulse enable: 1 = Transmission of link pulses enabled 0 = Link pulses disabled, good link condition forced This bit is valid only in 10Mbps operation.
18.13	HBE	1, RW	Heartbeat enable: 1 = Heartbeat function enabled 0 = Heartbeat function disabled When the PHY is configured for full duplex operation, this bit will be ignored (the collision/heartbeat function is invalid in full duplex mode).
18.12	SQUELCH	1, RW	Squelch enable : 1 = normal squelch 0 = low squelch
18.11	JABEN	1, RW	Jabber Enable: Enables or disables the Jabber function when the PHY is in 10BASE-T full duplex or 10BASE-T transceiver loopback mode 1 = Jabber function enabled 0 = Jabber function disabled
18.10-18.1	RESERVED	0, RO	Reserved: Write as 0, ignore on read
18.0	POLR	0, RO	Polarity reversed: When this bit is set to 1, it indicates that the 10Mbps cable polarity is reversed. This bit is set and cleared by 10BASE-T module automatically.

Functional Description

Host Interface

There are two host interface modes: the ISA BUS compatible mode and the general processor mode. The difference of these two modes is the decoding of the chip selection of the DM9000. In the ISA compatible mode, the chip selection is decoded by pins ANE=0, SA[9:7]=000 and SA[6:4]=IO_base which are latched from strap pins or loaded from the EEPROM. While in the general processor mode, the chip selection is just coming from pin 3 (CS).

There are only two addressing ports through the access of the host interface.

One port is the INDEX port and the other is the DATA port. The INDEX port is decoded by the CMD pin=0 and the DATA by the CMD pin=1. The contents of the INDEX port are the register address of the DATA port. Before the access of any register, the address of the register must be saved in the INDEX port before.

Direct Memory Access Control

The DM9000 provides DMA capability to simplify the access of the internal memory. After the programming of the starting address of the internal memory and then issuing a dummy read/write command to load the current data to internal data buffer, the desired location of the internal memory can be accessed by the read/write command registers. The memory's address will be increased with the size equal to the current operation mode (i.e. the byte, word or double-word mode) and the data of the next location will be loaded to internal data buffer automatically. It is noted that the data of the first access (the dummy read/write command) in a sequential burst should be ignored because that the data was the contents of the last read/write command.

The internal memory size is 16K bytes. The first location of 3K bytes is used for the data buffer of the packet transmission. The other 13K bytes are used for the buffer of the receiving packets. So in the write memory operation, when the bit 7 of IMR is set, the

memory address increment will wrap to location 0 if the end of address (i.e. 3K) is reached. In a similar way, in the read memory operation, when the bit 7 of IMR is set, the memory address increment will wrap to location 0x0C00 if the end of address (i.e. 16K) is reached.

Packet Transmission

There are two packets, sequentially named as index I and index II, can be stored in the TX SRAM at the same time. The index register 02h controls the insertion of CRC and pads. Their statuses are recorded at index registers 03h and 04h respectively.

The start address of transmission is 00h and the current packet is index I after software or hardware reset. Firstly write data to the TX SRAM using the DMA port and then write the byte count to byte_count register at index register 0fch and 0fdh. Set the bit 1 of control register. The DM9000 starts to transmit the index I packet. Before the transmission of the index I packet ends, the data of the next (index II) packet can be moved to TX SRAM. After the index I packet ends the transmission, write the byte count data of the index II to BYTE_COUNT register and then set the bit 1 of control register to transmit the index II packet. The following packets, named index I, II, I, II, ..., use the same way to be transmitted.

Packet Reception

The RX SRAM is a ring data structure. The start address of RX SRAM is 0C00h after software or hardware reset. Each packet has a 4-byte header followed with the data of the reception packet which CRC field is included. The format of the 4-byte header is 01h, status, BYTE_COUNT low, and BYTE_COUNT high. It is noted that the start address of each packet is in the proper address boundary which depends on the operation mode (byte, word, or double-word mode).

100Base-TX Operation

The block diagram in figure 3 provides an overview of the functional blocks contained in the transmit section. The transmitter section contains the following functional blocks:

- 4B5B Encoder
- Scrambler
- Parallel to Serial Converter
- NRZ to NRZI Converter
- NRZI to MLT-3
- MLT-3 Driver

4B5B Encoder

The 4B5B encoder converts 4-bit (4B) nibble data generated by the MAC Reconciliation Layer into a 5-bit (5B) code group for transmission, reference Table 1. This conversion is required for control and packet data to be combined in code groups. The 4B5B encoder substitutes the first 8 bits of the MAC preamble with a J/K code-group pair (11000 10001) upon transmit. The 4B5B encoder continues to replace subsequent 4B preamble and data nibbles with corresponding 5B code-groups. At the end of the transmit packet, upon the deassertion of the Transmit Enable signal from the MAC Reconciliation layer, the 4B5B encoder injects the T/R code-group pair (01101 00111) indicating end of frame. After the T/R code-group pair, the 4B5B encoder continuously injects IDLEs into the transmit data stream until Transmit Enable is asserted and the next transmit packet is detected.

The DM9000 includes a Bypass 4B5B conversion option within the 100Base-TX Transmitter for support of applications like 100 Mbps repeaters which do not require 4B5B conversion.

Scrambler

The scrambler is required to control the radiated emissions (EMI) by spreading the transmit energy across the frequency spectrum at the media connector and on the twisted pair cable in 100Base-TX operation.

By scrambling the data, the total energy presented to the cable is randomly distributed over a wide frequency range. Without the scrambler, energy levels on the cable could peak beyond FCC limitations at frequencies related to repeated 5B sequences like continuous transmission of IDLE symbols. The scrambler output is combined with the NRZ 5B data from the code-group encoder via an XOR logic function. The result is a scrambled data stream with sufficient randomization to decrease radiated emissions at critical frequencies.

Parallel to Serial Converter

The Parallel to Serial Converter receives parallel 5B scrambled data from the scrambler and serializes it (converts it from a parallel to a serial data stream). The serialized data stream is then presented to the NRZ to NRZI Encoder block

NRZ to NRZI Encoder

After the transmit data stream has been scrambled and serialized, the data must be NRZI encoded for compatibility with the TP-PMD standard for 100Base-TX transmission over Category-5 unshielded twisted pair cable.

MLT-3 Converter

The MLT-3 conversion is accomplished by converting the data stream output from the NRZI encoder into two binary data streams with alternately phased logic one events.

MLT-3 Driver

The two binary data streams created at the MLT-3 converter are fed to the twisted pair output driver which converts these streams to current sources and alternately drives either side of the transmit transformer primary winding resulting in a minimal current MLT-3 signal. Refer to figure 4 for the block diagram of the MLT-3 converter.

4B5B Code Group

Symbol	Meaning	4B code 3210	5B Code 43210
0	Data 0	0000	11110
1	Data 1	0001	01001
2	Data 2	0010	10100
3	Data 3	0011	10101
4	Data 4	0100	01010
5	Data 5	0101	01011
6	Data 6	0110	01110
7	Data 7	0111	01111
8	Data 8	1000	10010
9	Data 9	1001	10011
A	Data A	1010	10110
B	Data B	1011	10111
C	Data C	1100	11010
D	Data D	1101	11011
E	Data E	1110	11100
F	Data F	1111	11101
I	Idle	undefined	11111
J	SFD (1)	0101	11000
K	SFD (2)	0101	10001
T	ESD (1)	undefined	01101
R	ESD (2)	undefined	00111
H	Error	undefined	00100
V	Invalid	undefined	00000
V	Invalid	undefined	00001
V	Invalid	undefined	00010
V	Invalid	undefined	00011
V	Invalid	Undefined	00101
V	Invalid	undefined	00110
V	Invalid	undefined	01000
V	Invalid	undefined	01100
V	Invalid	undefined	10000
V	Invalid	undefined	11001

Table 1

100Base-TX Receiver

The 100Base-TX receiver contains several function blocks that convert the scrambled 125Mb/s serial data to synchronous 4-bit nibble data that is then provided to the MII.

The receive section contains the following functional blocks:

- Signal Detect
- Digital Adaptive Equalization
- MLT-3 to Binary Decoder
- Clock Recovery Module
- NRZI to NRZ Decoder
- Serial to Parallel
- Descrambler
- Code Group Alignment
- 4B5B Decoder

Signal Detect

The signal detect function meets the specifications mandated by the ANSI XT12 TP-PMD 100Base-TX Standards for both voltage thresholds and timing parameters.

Adaptive Equalization

When transmitting data at high speeds over copper twisted pair cable, attenuation based on frequency becomes a concern. In high speed twisted pair signaling, the frequency content of the transmitted signal can vary greatly during normal operation based on the randomness of the scrambled data stream. This variation in signal attenuation caused by frequency variations must be compensated for to ensure the integrity of the received data. In order to ensure quality transmission when employing MLT-3 encoding, the compensation must be able to adapt to various cable lengths and cable types depending on the installed environment. The selection of long cable lengths for a given implementation, requires significant compensation which will be over-kill in a situation that includes shorter, less attenuating cable lengths. Conversely, the selection of short or intermediate cable lengths requiring less compensation will cause serious under-compensation for longer length cables. Therefore, the compensation or equalization must be adaptive to ensure proper conditioning of the received signal independent of the

cable length.

MLT-3 to NRZI Decoder

The DM9000 decodes the MLT-3 information from the Digital Adaptive Equalizer into NRZI data. The relationship between NRZI and MLT-3 data is shown in figure 4.

Clock Recovery Module

The Clock Recovery Module accepts NRZI data from the MLT-3 to NRZI decoder. The Clock Recovery Module locks onto the data stream and extracts the 125Mhz reference clock. The extracted and synchronized clock and data are presented to the NRZI to NRZ Decoder.

NRZI to NRZ

The transmit data stream is required to be NRZI encoded in for compatibility with the TP-PMD standard for 100Base-TX transmission over Category-5 unshielded twisted pair cable. This conversion process must be reversed on the receive end. The NRZI to NRZ decoder, receives the NRZI data stream from the Clock Recovery Module and converts it to a NRZ data stream to be presented to the Serial to Parallel conversion block.

Serial to Parallel

The Serial to Parallel Converter receives a serial data stream from the NRZI to NRZ converter, and converts the data stream to parallel data to be presented to the descrambler.

Descrambler

Because of the scrambling process required to control the radiated emissions of transmit data streams, the receiver must descramble the receive data streams. The descrambler receives scrambled parallel data streams from the Serial to Parallel converter, descrambles the data streams, and presents the data streams to the Code Group alignment block.

Code Group Alignment

The Code Group Alignment block receives un-aligned 5B data from the descrambler and converts it into 5B code group data. Code Group Alignment occurs after the J/K is detected, and subsequent data is aligned on a fixed boundary.

4B5B Decoder

The 4B5B Decoder functions as a look-up table that translates incoming 5B code groups into 4B (Nibble) data. When receiving a frame, the first 2 5-bit code groups received are the start-of-frame delimiter (J/K symbols). The J/K symbol pair is stripped and two nibbles of preamble pattern are substituted. The last two code groups are the end-of-frame delimiter (T/R symbols).

The T/R symbol pair is also stripped from the nibble presented to the Reconciliation layer.

10Base-T Operation

The 10Base-T transceiver is IEEE 802.3u compliant. When the DM9000 is operating in 10Base-T mode, the coding scheme is Manchester. Data processed for transmit is presented to the MII interface in nibble format, converted to a serial bit stream, then Manchester encoded. When receiving, the Manchester encoded bit stream is decoded and converted into nibble format for presentation to the MII interface.

Collision Detection

For half-duplex operation, a collision is detected when the transmit and receive channels are active simultaneously. When a collision has been detected, it will be reported by the COL signal on the MII interface. Collision detection is disabled in Full Duplex operation.

Carrier Sense

Carrier Sense (CRS) is asserted in half-duplex operation during transmission or reception of data. During full-duplex mode, CRS is asserted only during receive operations.

Auto-Negotiation

The objective of Auto-negotiation is to provide a means to exchange information between segment linked devices and to automatically configure both devices to take maximum advantage of their abilities. It is important to note that Auto-negotiation does not test the link segment characteristics. The Auto-Negotiation function provides a means for a device to advertise supported modes of operation to a remote link partner, acknowledge the receipt and understanding of common modes of operation, and to reject un-shared modes of operation. This allows devices on both ends of a segment to establish a link at the best common mode of operation. If more than one common mode exists between the two devices, a mechanism is provided to allow the devices to resolve to a single mode of operation using a predetermined priority resolution function.

Auto-Negotiation (continued)

Auto-negotiation also provides a parallel detection function for devices that do not support the Auto-negotiation feature. During Parallel detection there is no exchange of configuration information, instead, the receive signal is examined. If it is discovered that the signal matches a technology that the receiving device supports, a connection will be automatically established using that technology. This allows devices that do not support Auto-negotiation but support a common mode of operation to establish a link.

Power Reduced Mode

The Signal detect circuit is always turned on to monitor the signal if there is no signal on the media (cable disconnected). The DM9000 automatically turns off the power and enters the Power Reduced mode, whether its operation mode is N-way or force mode. When enters the Power Reduced mode, the transmit circuit still sends out fast link pulses with minimum power consumption. If a valid signal is detected from the media, which might be N-ways fast link pulses, 10Base-T normal link pulses, or 100Base-TX MLT3 signals, the device wakes up and resumes normal operation mode.

That can be writing Zero to Reg.16.4 to disable Power Reduced mode.

- **Power Down Mode**

That can be setting Reg.0.11 high to enter the Power Down mode, which disables all transmit, receive functions and MII interface functions except the MDC/MDIO management interface.

- **Reduced Transmit Power Mode**

Additional Transmit power reduction can be gained by designing with 1.25:1 turns ration magnetic on its TX side and using a 8.5K Ω resistor on BGRES and BGGND pins, and the TX+/TX- pull-high resistors should be changed from 50 Ω to 78 Ω . This configuration could be reduced about 20% transmit power.

**Absolute Maximum Ratings****Absolute Maximum Ratings (25°C)**

Symbol	Parameter	Min.	Max.	Unit	Conditions
DVDD AVDD	Supply Voltage	-0.3	3.6	V	
VIN	DC Input Voltage (VIN)	-0.5	5.5	V	
VOUT	DC Output Voltage(VOUT)	-0.3	3.6	V	
Tstg	Storage Temperature Rang (Tstg)	-65	+150	°C	EIAJ-4701
Tc	Case Temperature	0	85	°C	Air Flow = 0m/min
LT	Lead Temp. (TL, Soldering, 10 sec.)	---	235	°C	J-STD-020A
ESD	ESD rating (Rzap=1.5k Czap=100PF)		4000	V	Human Body Mode

Operating Conditions

Symbol	Parameter	Min.	Max.	Unit	Conditions
DVDD,AVDD	Supply Voltage	3.135	3.465	V	
Tc	Case Temperature	---	85	°C	
PD (Power Dissipation)	100BASE-TX	---	100	mA	3.3V
	10BASE-T TX	---	85	mA	3.3V
	10BASE-T idle	---	44	mA	3.3V
	Auto-negotiation	---	60	mA	3.3V
	Power Reduced Mode(without cable)	---	20	mA	3.3V
	Power Down Mode	---	10	mA	3.3V

Comments

Stresses above those listed under “Absolute Maximum Ratings” may cause permanent damage to the device. These are stress ratings only. Functional operation of this device at these or any other conditions above those indicated in the operational

sections of this specification is not implied. Exposure to absolute maximum rating conditions for extended periods may affect device reliability.



DC Electrical Characteristics (V_{CC} = 3.3V)

Symbol	Parameter	Min.	Typ.	Max.	Unit	Conditions
TTL Inputs (TXD0~TXD3, TXCLK, MDC, MDIO, TXEN, TXER, RXEN, TESTMODE, RMII, PHYAD0~4, OPMODE0-2, RPTR, BP4B5B, RESET#)						
V _{IL}	Input Low Voltage	---	---	0.8	V	
V _{IH}	Input High Voltage	2.0	---	---	V	
I _{IL}	Input Low Leakage Current	---	---	1	uA	V _{IN} = 0.4V
I _{IH}	Input High Leakage Current	---	---	-1	uA	V _{IN} = 2.7V
MII TTL Outputs (RXD0-RXD3, RXDV, RXER, CRS, COL, MDIO)						
V _{OL}	Output Low Voltage	---	---	0.4	V	I _{OL} = 4mA
V _{OH}	Output High Voltage	2.4	---	---	V	I _{OH} = -4mA
Non-MII TTL Outputs (LINKLED#, SPEEDLED#, FDXLED#, MDINTR#)						
V _{OL}	Output Low Voltage	---	---	0.4	V	I _{OL} = 1mA
V _{OH}	Output High Voltage	2.4	---	---	V	I _{OH} = -0.1mA
Receiver						
V _{ICM}	RX+/RX- Common mode Input Voltage	---	0.9	---	V	100 Ω Termination Across
Transmitter						
V _{TD100}	100TX+/- Differential Output Voltage	1.9	2.0	2.1	V	Peak to Peak
V _{TD10}	10TX+/- Differential Output Voltage	4.4	5	5.6	V	Peak to Peak
I _{TD100}	100TX+/- Differential Output Current	19	20	21	mA	
I _{TD10}	10TX+/- Differential Output Current	44	50	56	mA	

AC Electrical Characteristics & Timing Waveforms

TP Interface

Symbol	Parameter	Min.	Typ.	Max.	Unit	Conditions
tTR/F	100TX+/- Differential Rise/Fall Time	3.0	---	5.0	ns	
tTM	100TX+/- Differential Rise/Fall Time Mismatch	0	---	0.5	ns	
tDC	100TX+/- Differential Output Duty Cycle Distortion	0	---	0.5	ns	
tT/T	100TX+/- Differential Output Peak-to-Peak Jitter	0	---	1.4	ns	
XOST	100TX+/- Differential Voltage Overshoot	0	---	5	%	

Oscillator/Crystal Timing

Symbol	Parameter	Min.	Typ.	Max.	Unit	Conditions
tCKC	tCKC	39.998	40	40.002	ns	50ppm
tPWH	tCKC	16	20	24	ns	
tPWL	OSC Pulse Width Low	16	20	24	ns	

Processor Register Read Timing

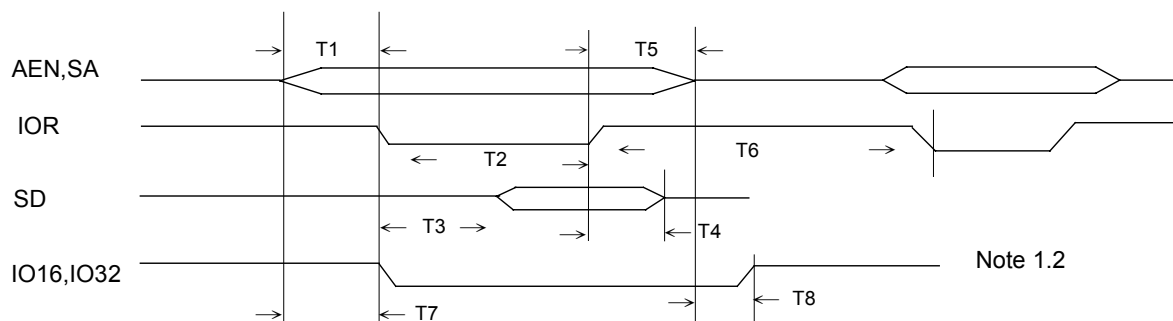

Symbol	Parameter	Min.	Typ.	Max.	Unit
T1	System address valid to IOR valid	5			ns
T2	IOR with SD in valid	22			ns
T3	IOR valid to SD in valid			10	ns
T4	IOR invalid to SD invalid			4	ns
T5	IOR invalid to system address invalid	5			ns
T6	IOR invalid to next IOR valid (access DM9000)	80			ns
T7	System address valid to IO16,IO32 valid			5	ns
T8	System address invalid to IO16,IO32 invalid			5	ns

Note :

1. The IO16 is valid when the SD bus width is 16-bit or 32-bit and system address is data port (i.e. SA0 is high) and the value of address port is memory data register index (ex. F0H, F2H, F6H or F8H)
2. The IO32 is valid when the SD bus width is 32-bit and system address is data port (i.e. SA is high) and the value of address port is memory data register index (ex. F0H, F2H, F6H or F8H)

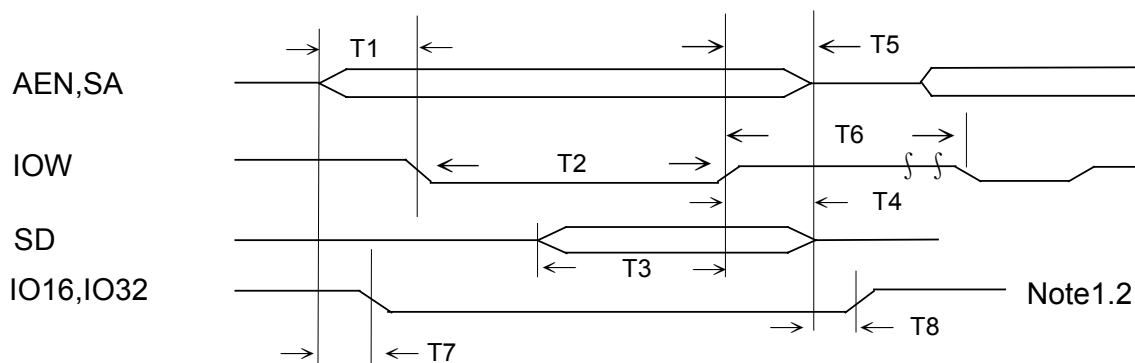
Processor Register Write Timing

Symbol	parameter	Min.	Typ.	Max.	Unit
T1	System address valid to IOW valid	5			ns
T2	IOW width	22			ns
T3	SD setup time	5			ns
T4	SD hold time	5			ns
T5	IOW invalid to system address invalid	5			ns
T6	IOW invalid to next IOW (access DM9000)	80			ns
T7	System address valid to IO16,IO32 valid			5	ns
T8	System address invalid to IO16,IO32 invalid			5	ns

Note :

1. The IO16 is valid when the SD bus width is 16-bit or 32-bit and system address is data port (i.e. SA0 is high) and the value of address port is memory data register index (ex. F0H, F2H, F6H or F8H)
2. The IO32 is valid when the SD bus width is 32-bit and system address is data port (i.e. SA is high) and the value of address port is memory data register index (ex. F0H, F2H, F6H or F8H)

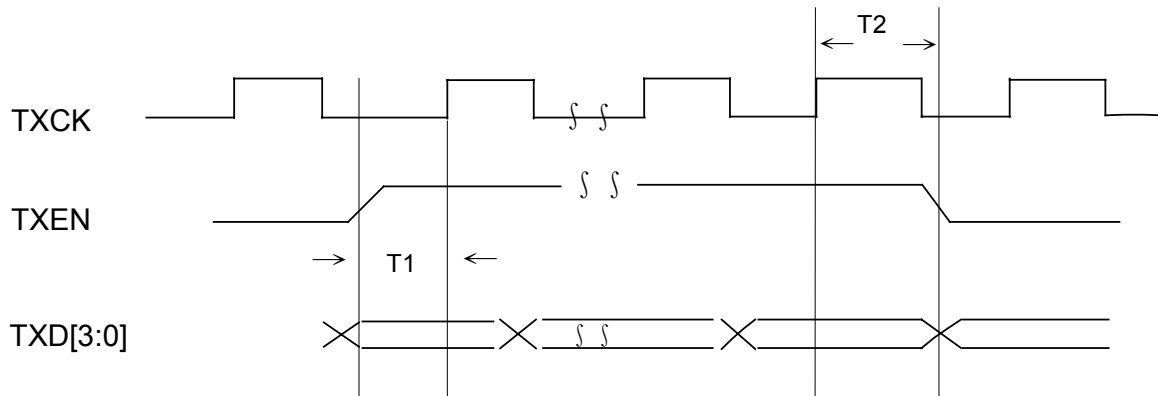
External MII Interface Transmit Timing

Symbol	parameter	Min.	Typ.	Max.	Unit
T1	TXEN, TXD[3 : 0] Setup time		32		ns
T2	TXEN, TXD[3 : 0] hold time		8		ns

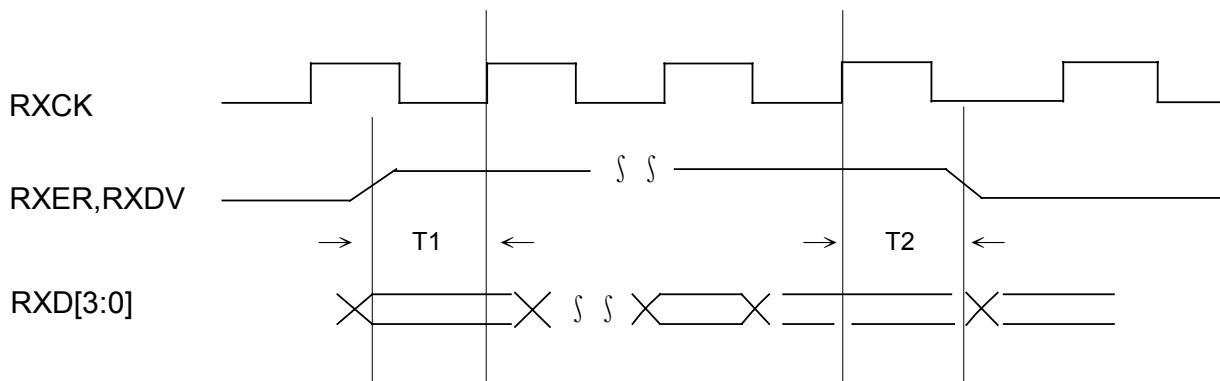
External MII Interface Receive Timing

Symbol	parameter	Min.	Typ.	Max.	Unit
T1	RXER, RXDV, RXD[3 : 0] Setup time	5			ns
T2	RXER, RXDV, RXD[3 : 0] hold time	5			ns

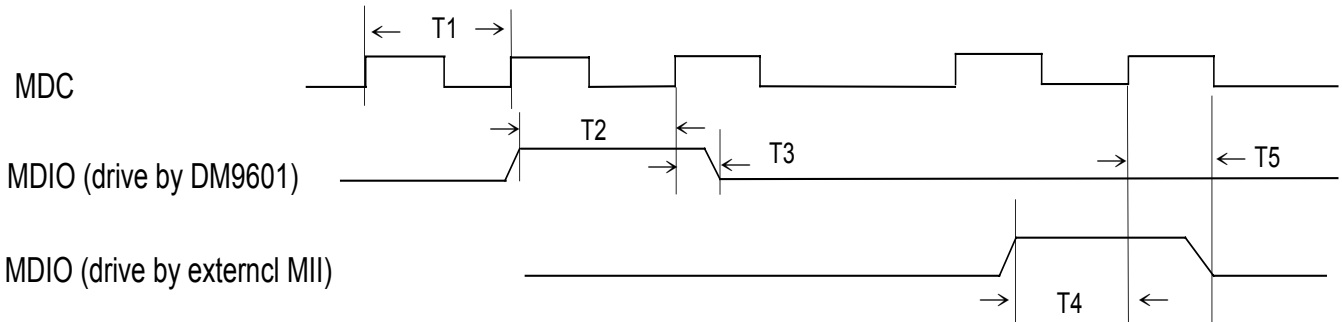
MII Management Interface Timing

Symbol	parameter	Min.	Typ.	Max.	Unit
T1	MDC frequency		2		Mhz
T2	MDIO by DM9000 setup time		187		ns
T3	MDIO by DM9000 hold time		313		ns
T4	MDIO by external MII setup time	40			ns
T5	MDIO by external MII hold time	40			ns

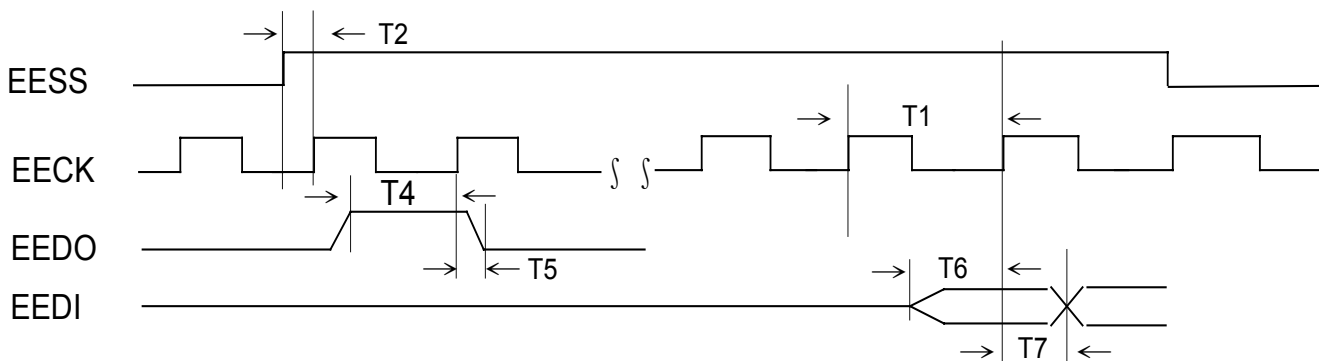
EEPROM Interface Timing

Symbol	parameter	Min.	Typ.	Max.	Unit
T1	EECK frequency		500		ns
T2	EESCS setup time		0.375		Mhz
T3	EESCS hold time		2166		ns
T4	EEDO setup time		480		ns
T5	EEDO hold time		2200		ns
T6	EEDI setup time	80			ns
T7	EEDI hold time	80			ns

Application Notes

Network Interface Signal Routing

Place the transformer as close as possible to the RJ-45 connector. Place all the 50Ω resistors as close as possible to the DM9000 RX± and TX± pins. Traces routed from RX± and TX± to the transformer should run in close pairs directly to the transformer. The designer should be careful not to cross the transmit and receive pairs. As always, vias should be avoided as much as possible. The network interface are should be void of any signals other than the TX ± and RX ± pairs between the RJ-45 to the transformer and the transformer to the DM9000.. There should be no power or ground planes in the area under the network side

of the transformer to include the area under the RJ-45 connector. (Refer to Figure 4 and 5) keep chassis ground away from all active signals. The RJ-45 connector and any unused pins should be tied to chassis ground through a resistor divider network and a 2KV bypass capacitor.

The Band Gap resistor should be placed as physically close as pins 25 and 26 as possible (refer to Figure 1 and 2). The designer should not run any high-speed signal near the Band Gap resistor placement.

1. 10Base-T/100Base-TX Application

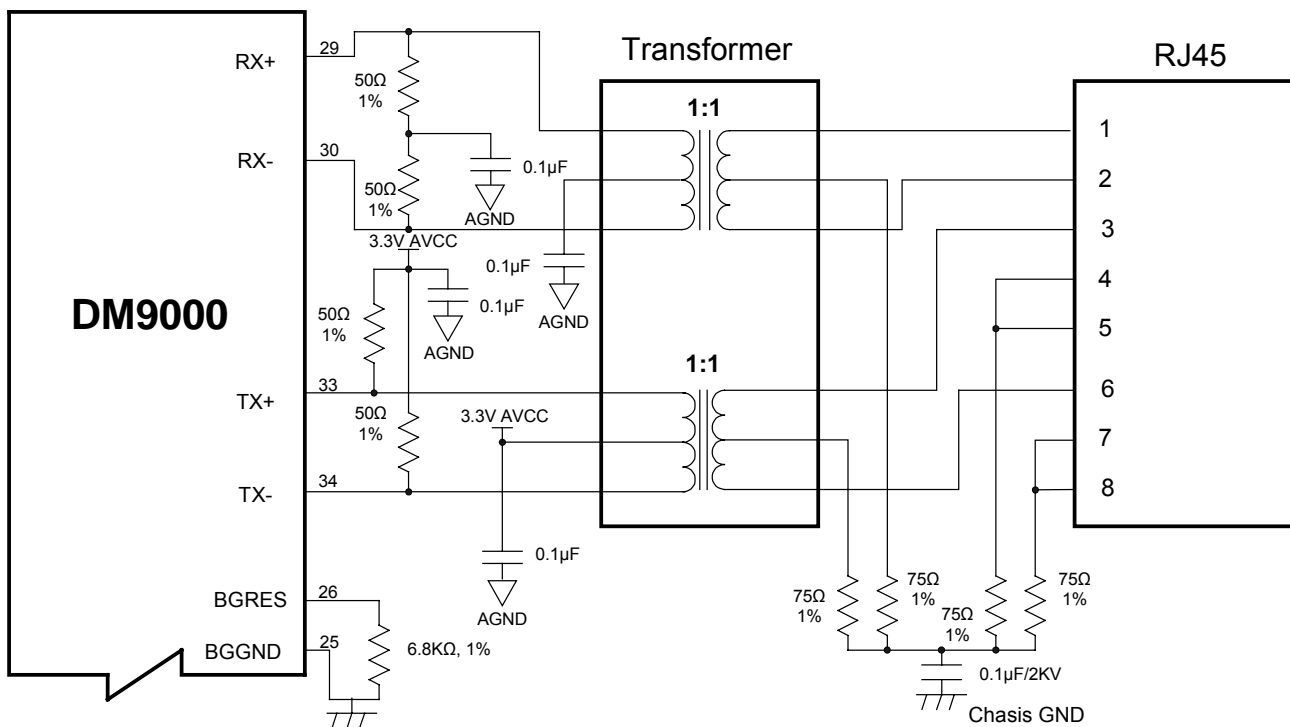

Figure 1

2.10Base-T/100Base-TX (Power Reduction Application)

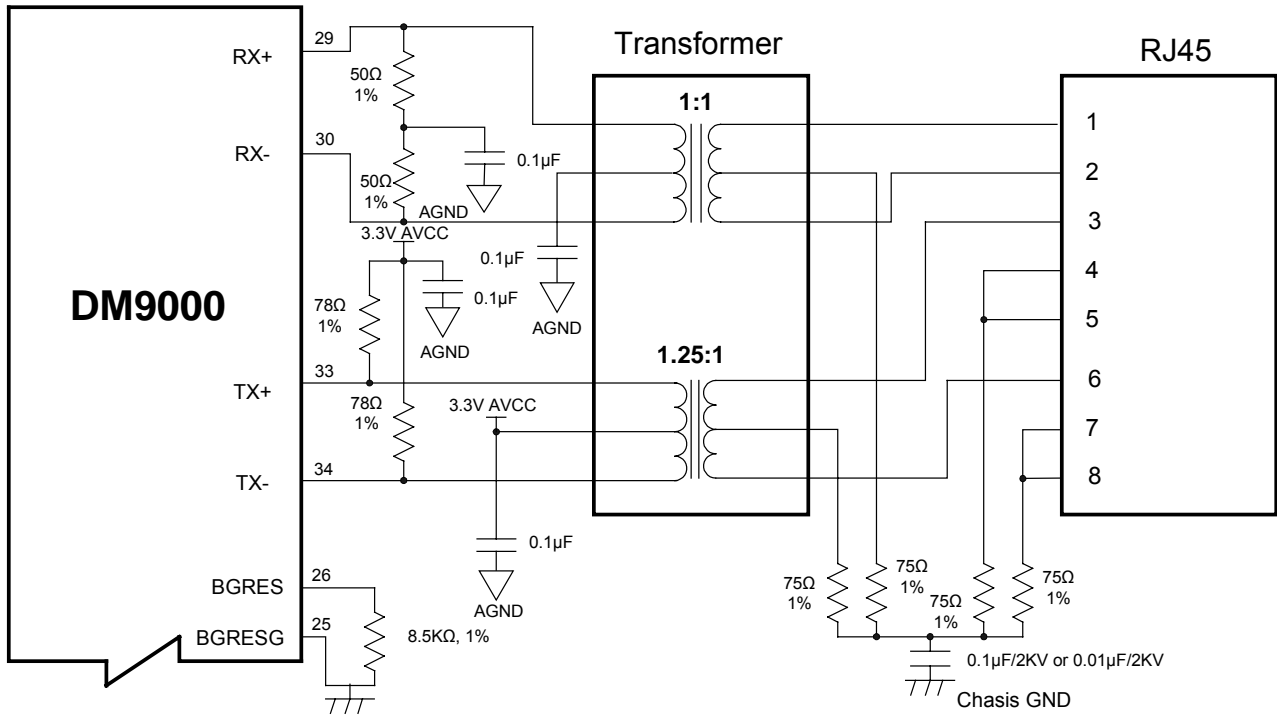

Figure 2

3. Power Decoupling Capacitors

Davicom Semiconductor recommends placing all the decoupling capacitors for all power supply pins as close as possible to the power pads of the DM9000 (The best placed distance is $< 3\text{mm}$ from pin). The recommended

decoupling capacitor is $0.1\ \mu\text{F}$ or $0.01\ \mu\text{F}$, as required by the design layout.

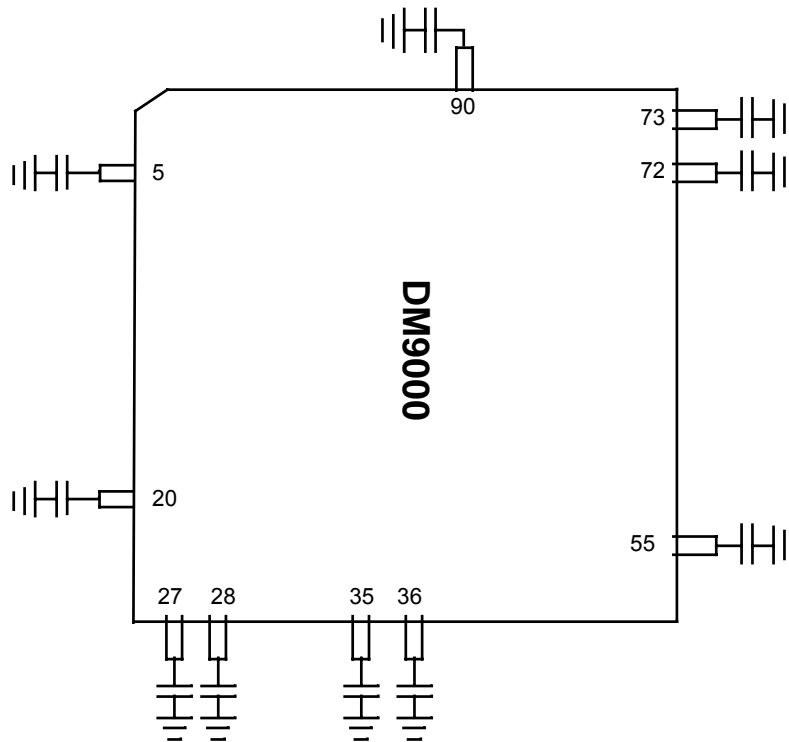

Figure 3

4. Ground Plane Layout

Davicom Semiconductor recommends a single ground plane approach to minimize EMI. Ground plane partitioning can cause increased EMI emissions that could make the

network interface card not comply with specific FCC regulations (part 15). Figure 4 shows a recommended ground layout scheme.

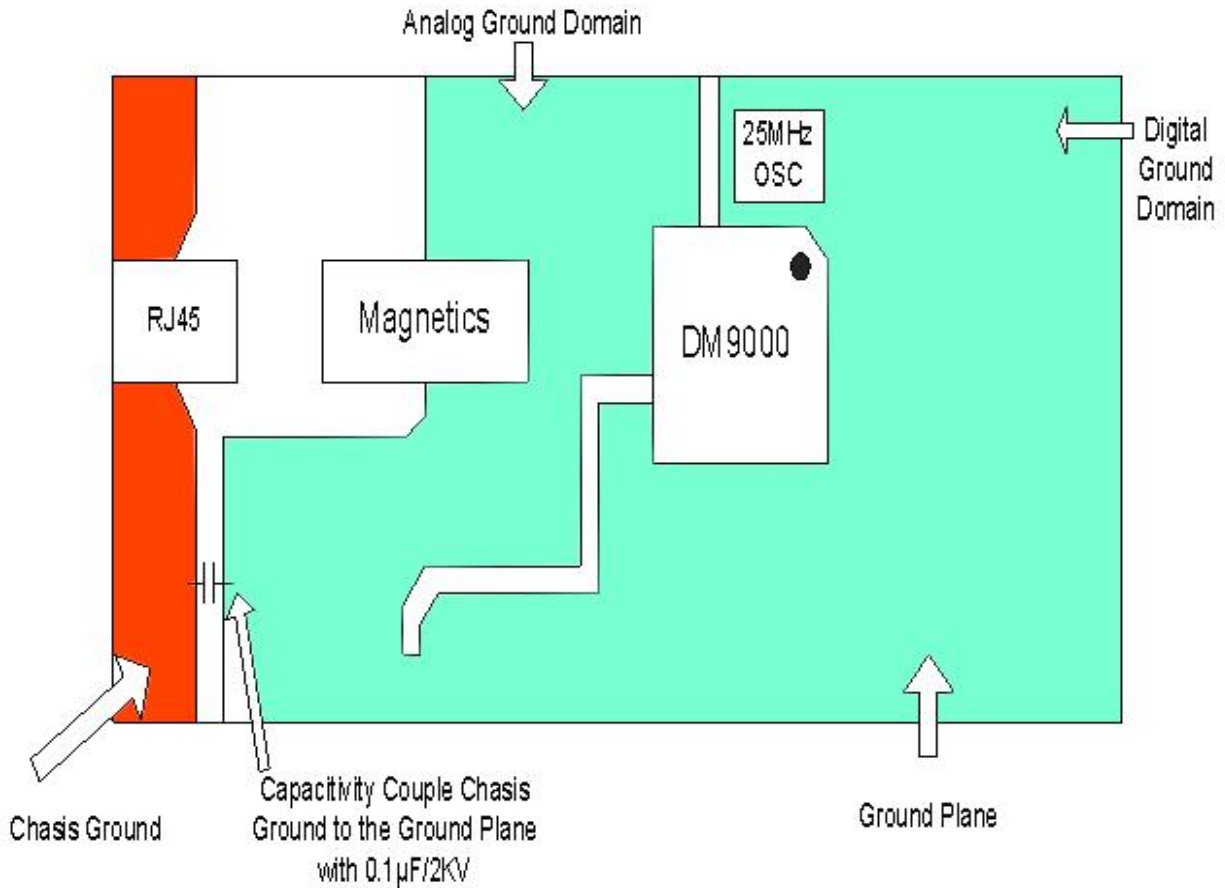

Figure 4

5. Power Plane Partitioning

The power planes should be approximately illustrated in Figure 5. The ferrite bead used should have an impedance at least 75Ω at 100MHz. A suitable bead is the Panasonic surface mount bead, part number EXCCL4532U or

equivalent. A $10\mu F$ electrolytic bypass capacitors should be connected between VCC and Ground at the device side of each of the ferrite bead.

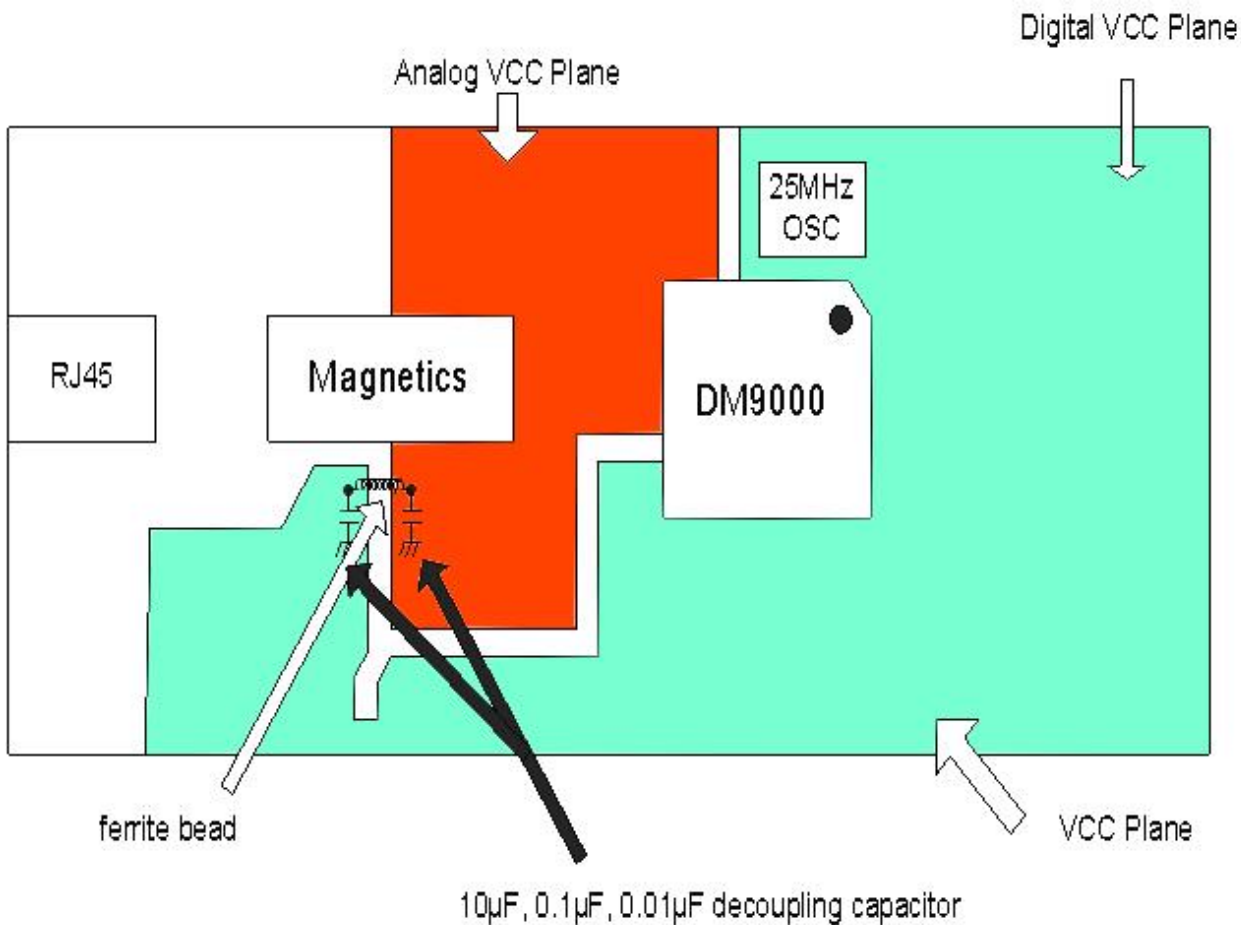

Figure 5

Magnetics Selection Guide

Refer to Table 2 for transformer requirements. Transformers meeting these requirements are available from a variety of magnetic manufacturers. Designers should test and qualify all magnetics before

using them in an application. The transformers listed in Table 2 are electrical equivalents, but may not be pin-to-pin equivalents.

Manufacturer	Part Number
Pulse Engineering	PE-68515, H1078, H1012 H1102
Delta	LF8200, LF8221x
YCL	20PMT04, 20PMT05
Halo	TG22-3506ND, TD22-3506G1, TG22-S010ND TG22-S012ND
Nano Pulse Inc.	NPI 6181-37, NPI 6120-30, NPI 6120-37 NPI 6170-30
Fil-Mag	PT41715
Bel Fuse	S558-5999-01
Valor	ST6114, ST6118
Macronics	HS2123, HS2213

Table 2
Crystal Selection Guide

A crystal can be used to generate the 25Mhz reference clock instead of a oscillator. The crystal must be a fundamental type, series-resonant.

Connect to X1 and X2, shunt each crystal lead to ground with a 22pf capacitor (see figure 6).

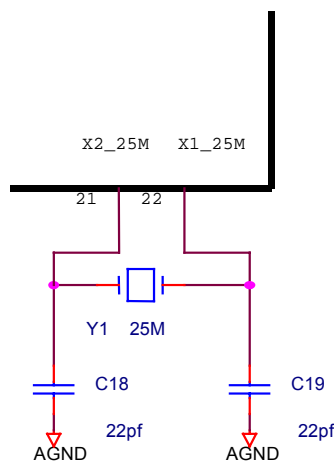
**Figure 6
Crystal Circuit Diagram**

Package Information
LQFP 100L Outline Dimensions

Unit: Inches/mm

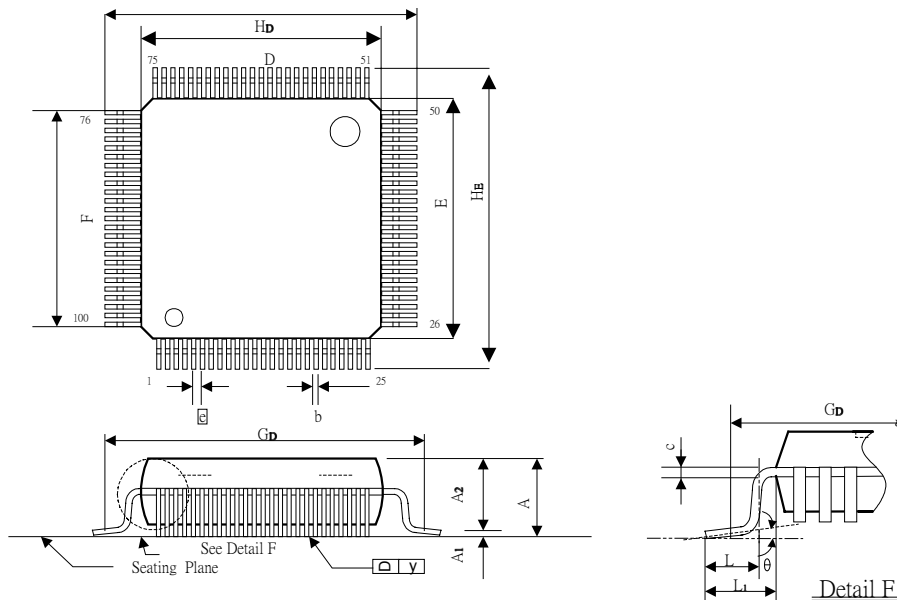

Symbol	Dimensions In Inches	Dimensions In mm
A	0.063 Max.	1.60 Max.
A1	0.004 ± 0.002	0.1 ± 0.05
A2	0.055 ± 0.002	1.40 ± 0.05
b	0.009 ± 0.002	0.22 ± 0.05
c	0.006 ± 0.002	0.15 ± 0.05
D	0.551 ± 0.005	14.00 ± 0.13
E	0.551 ± 0.005	14.00 ± 0.13
e	0.020 BSC.	0.50 BSC.
F	0.481 NOM.	12.22 NOM.
GD	0.606 NOM.	15.40 NOM.
HD	0.630 ± 0.006	16.00 ± 0.15
HE	0.630 ± 0.006	16.00 ± 0.15
L	0.024 ± 0.006	0.60 ± 0.15
L ₁	0.039 Ref.	1.00 Ref.
y	0.004 Max.	0.1 Max.
θ	0° ~ 12°	0° ~ 12°

Notes:

1. Dimension D & E do not include resin fins.
2. Dimension GD is for PC Board surface mount pad pitch design reference only.
3. All dimensions are based on metric system.



Ordering Information

Part Number	Pin Count	Package
DM9000E	100	LQFP

Disclaimer

The information appearing in this publication is believed to be accurate. Integrated circuits sold by DAVICOM Semiconductor are covered by the warranty and patent indemnification provisions stipulated in the terms of sale only. DAVICOM makes no warranty, express, statutory, implied or by description regarding the information in this publication or regarding the information in this publication or regarding the freedom of the described chip(s) from patent infringement. FURTHER, DAVICOM MAKES NO WARRANTY OF MERCHANTABILITY OR FITNESS FOR ANY PURPOSE. DAVICOM reserves the right to halt production or alter the specifications and prices at any time without notice. Accordingly, the reader is cautioned to verify that the data sheets and other information in this publication are current before placing orders. Products described herein are intended for use in normal commercial applications. Applications involving unusual environmental or reliability requirements, e.g. military equipment or medical life support equipment, are specifically not recommended without additional processing by DAVICOM for such applications. Please note that application circuits illustrated in this document are for

reference purposes only.

DAVICOM's terms and conditions printed on the order acknowledgment govern all sales by DAVICOM. DAVICOM will not be bound by any terms inconsistent with these unless DAVICOM agrees otherwise in writing. Acceptance of the buyer's orders shall be based on these terms.

Company Overview

DAVICOM Semiconductor Inc. develops and manufactures integrated circuits for integration into data communication products. Our mission is to design and produce IC products that are the industry's best value for Data, Audio, Video, and Internet/Intranet applications. To achieve this goal, we have built an organization that is able to develop chipsets in response to the evolving technology requirements of our customers while still delivering products that meet their cost requirements.

Products

We offer only products that satisfy high performance requirements and which are compatible with major hardware and software standards. Our currently available and soon to be released products are based on our proprietary designs and deliver high quality, high performance chipsets that comply with modern communication standards and Ethernet networking standards.

Contact Windows

For additional information about DAVICOM products, contact the sales department at:

Headquarters

Hsin-chu Office:

3F, No. 7-2, Industry E. Rd., IX,
Science-based Park,
Hsin-chu City, Taiwan, R.O.C.
TEL: 886-3-5798797
FAX: 886-3-5798858

Taipei Sales & Marketing Office:

8F, No. 3, Lane 235, Bao-chiao Rd.,
Hsin-tien City, Taipei, Taiwan, R.O.C.
TEL: 886-2-29153030
FAX: 886-2-29157575
Email: sales@davicom.com.tw
Web site: <http://www.davicom.com.tw>

WARNING

Conditions beyond those listed for the absolute maximum may destroy or damage the products. In addition, conditions for sustained periods at near the limits of the operating ranges will stress and may temporarily (and permanently) affect and damage structure, performance and/or function.

APPENDIX:**1. Data sheet changed errata list**

05/02//2001 P01 DM9000 Data Sheet start

06/14/2001 P01 Page 1 Modify Block Diagram

06/22/2001 P01 Page 20

Before modification

4	BKPM	0,RW	Back pressure mode. This mode is for half duplex mode only. Generate a jam pattern when a packet's DA match and RX SRAM over BPHW.
3	BKPA	0,RW	Back pressure mode. This mode is for half duplex mode only. Generate a jam pattern when any packet coming and RX SRAM over BPHW.

After modification

4	BKPA	0,RW	Back pressure mode. This mode is for half duplex mode only. Generate a jam pattern when any packet coming and RX SRAM over BPHW.
3	BKPM	0,RW	Back pressure mode. This mode is for half duplex mode only. Generate a jam pattern when a packet's DA match and RX SRAM over BPHW.