

**Air Live**®

www.ovislink.com.tw

Live-FSH8SB

Fast Ethernet Switch

*8 × 10/100Mbps
NWay 10/100BASE-TX
Fast Ethernet Switch
with Auto-MDI/MDIX*

User's Manual



Made by OvisLink Corp.

Trademarks

All rights reserved.

AirLive Logo is an registered trademarks of OvisLink Corp, Taiwan. Other product names and company names are trademarks or registered trademarks of their respective owners.

FCC Warning

This equipment has been tested and found to comply with the requirements for a Class A digital device, pursuant to Part 15 of the FCC Rules. These requirements are designed for reasonable protection against harmful interference when the equipment operating in a commercial environment. This equipment can generate and radiate electromagnetic energy and, if not installed and used in accordance with this guide, may cause significant interference with radio communication. Operation of this equipment in a residential area is likely to cause interference to household appliances, in which case the user will be required to amend at his or her own expense.

CE Mark Warning

This is a Class A product. In a domestic environment, this product may cause radio interference, in which case the user may be required to take adequate preventive measures.

Disclaimer

Contents in this manual are subject to changes without prior notice.

About this *User's Manual*

This *User's Manual* aims at helping users to know the key features of **Live-FSH8SB Fast Ethernet Switch** and to install it in a **10/100BASE-TX Fast Ethernet Local Area Network (LAN)**.

OvisLink Corp

2F, No. 8, Lane 130, Min-Chuan Rd, Hsin-Tien City, Taipei, Taiwan, R.O.C.

Table of Contents

TABLE OF CONTENTS1

1 PRODUCT OVERVIEW1

Introduction..... 1
8× 10/100Mbps ports Fast Ethernet Switch..... 1
Store-and-Forward Architecture against Packet Loss..... 1
Active Flow Control 1
Full Wire Speed 1
System/Port Status Information at a Glance 1

Product Features..... 3
Basic Features 3

2 PREPARATION BEFORE INSTALLATION.....4

Unpack the Package..... 4

The Front Panel..... 5

The Rear Panel..... 5
Station Ports (Port #1 to #8)..... 5
DC Power Jack..... 5

3 INSTALLATION OF THE SWITCH.....6

Quick Installation.....	6
2 Steps to Quick Installation.....	6
Desktop Installation.....	6
Installation on Wall.....	7
Cabling Requirements.....	7
Cable requirement for 100BASE-TX Port.....	7
Straight-through cabling.....	7
Connecting to Power.....	9

4 EXPANDING YOUR NETWORK.....10

Connectivity Rules.....	10
10 Mbps Connection (10BASE-T).....	10
Twisted-pair 100Mbps Connection (100BASE-TX).....	10
Connecting to another Switch/Hub.....	11
Straight-through Cable Connection for Switch-to-Switch/hub Connection.....	11
Transmission Modes.....	12
Station Ports (10/100BASE-TX Transmission).....	12
LAN Micro segmentation through Switching Technology.....	12

5 LED INDICATORS.....13

Comprehensive LEDs.....	13
--------------------------------	-----------

System LED	13
Station Port LEDs	13
Power LED	13
Station Port LEDs	14
Link/Act LED	14
FDX/Col LED	14
100M	14
APPENDIX A PRODUCT SPECIFICATIONS	15
APPENDIX B TROUBLESHOOTING.....	17

Figures

Fig. 2-1 Package Content	4
Fig. 2-2 Front Panel	5
Fig. 2-3 Rear Panel	5
Fig. 3-1 Desktop installation.....	6
Fig. 3-2 Bottom View of the Switch (showing mounting holes).....	7
Fig. 3-3 10/100BASE-TX pin assignments for RJ-45 connector	8
Fig. 3-4 Pin assignments for straight-through cabling.....	8
Fig 3-5 Connecting the Switch to power outlet	9
Fig. 5-1 Front-panel LED indicators.....	13

Tables

Table 3-1 Cabling type for 10BASE-T/100BASE-TX.....	8
Table 5-1 Station Port LEDs.....	14

1 Product Overview

Introduction

8× 10/100Mbps ports Fast Ethernet Switch

Live-FSH8SB Fast Ethernet Switch is an auto-sensing and auto-negotiating 10/100BASE-TX Fast Ethernet Switch with VLAN and Priority capability. Its eight 10/100Mbps station ports provide 10/100Mbps connections to Ethernet/Fast Ethernet network.

Live-FSH8SB's unique switching fabric provides full wire speed for all ports. With auto-sensing, **Live-FSH8SB** automatically detects the speed of the devices you plug into, and routes the incoming data to its destination. Its auto-negotiating function allows existing devices running at different speeds to communicate easily within the same network.

Store-and-Forward Architecture against Packet Loss

When network is under heavy traffic, the shared memory buffer in the switching devices might yield incorrect detections due to overfed memory buffer. This setback can happen either when data is transmitted in IEEE802.3x Full Duplex or Back Pressure Flow Control mode. To solve this problem, **Live-FSH8SB** utilizes a fixed memory buffer allocation with Store-and-forward transmission to ensure an effective buffer allocation for each port.

Store-and-forward transmission controls data flow from transmitting to receiving nodes with the receiving buffer threshold adjusted to an optimal value, thus guaranteeing against all possible packet losses.

Active Flow Control

Live-FSH8SB Fast Ethernet Switch implements in full duplex mode a flow control that is compliant with the IEEE 802.3x standard. While in half duplex mode, it employs an optional Back Pressure Flow Control to stall the incoming data when port buffers are saturated. With this flow control mechanism, it can be ensured that frames dropped during transmission are reduced to a minimum.

Full Wire Speed

Live-FSH8SB's *Full Wire Speed feature* provides high-end performance for departmental and workgroup environments at a fraction of the cost of similar devices. Typically, this feature was found only in high-end switches designed to handle huge corporate networks. With bandwidth needs and network efficiency concerns, **Live-FSH8SB**'s switching fabric design is the perfect answer for bandwidth enhancement solution.

System/Port Status Information at a Glance

There are 2 sets of LEDs on the front panel: *System LEDs* and *Station Port LEDs*.

1 Product Overview

The System LEDs consist of the **Power**. Power LED shows Power On/Off status of the switch.

The **Station Port LEDs** reveal the link status, half/full duplex transmission, 10/100Mbps speed mode and the collision status of each station port.

For detailed LED information, refer to *Chapter 5, LED Indicators*.

Live-FSH8SB Fast Ethernet Switch

Product Features

The main features of Live-FSH8SB Fast Ethernet Switch are as follows:

Basic Features

- ❑ Fast Ethernet Switch with eight 10/100Mbps station ports
- ❑ Fully compliant with Ethernet/Fast Ethernet standards:
 - IEEE 802.3 (10 BASE-T Ethernet)
 - IEEE 802.3u (100 BASE-TX Fast Ethernet)
 - ANSI/IEEE Std 802.3 NWay auto-negotiation
- ❑ Fixed-port configuration:
 - 8 × 10/100 Mbps auto-sensing and auto-negotiating ports (Port #1 ~ 8)
- ❑ Easy plug-and-play installation
- ❑ Store and Forward transmission to prevent packet loss
- ❑ Half/Full Duplex function for all 10/100BASE-TX stations ports
- ❑ Auto-sensing and auto-MDI/MDIX function for all 10/100BASE-TX station ports
- ❑ Active Flow control to minimize frame drops
 - Half Duplex: Back Pressure control
 - Full Duplex: IEEE 802.3x compliant flow control
- ❑ Comprehensive LED indicators for system/port status monitoring:
 - System LEDs*
 - **Power** (green) LED to indicate power on/off status
 - Station Port LEDs (for port 1 ~ port8)*
 - Link/Act (green) LEDs to indicate linking status and activity in 10/100Mbps mode
 - FDX/Col (yellow) LEDs to indicate Half/Full Duplex transmission and collision status
 - 100M (red) LEDs to indicate 100 Mbps speed

2 Preparation before Installation

Unpack the Package

Before you begin the installation of **Live-FSH8SB** Fast Ethernet Switch, make sure that you have all the necessary accessories that come with your package. Follow the steps below to unpack your package contents:

1. Clear out an adequate space to unpack the package carton.
2. Open the package carton and take out the contents carefully.
3. Put back all the shipping materials such as plastic bag and linings into the package carton and save them for future transport need.

After unpacking and taking out the entire package contents, you should check whether you have got the following items:

- Live-FSH8SB** Fast Ethernet Switch
- One AC power adapter
- Support CD-ROM (The PDF version of this *User's Manual* can be found within)

If any of these above items is missing or damaged, please contact your local dealer for replacement.



Fig. 2-1 Package Content

The Front Panel

The front panel is where you can find the LED indicators. For information concerning LED indicators, please refer to *Chapter 5, LED Indicators*.

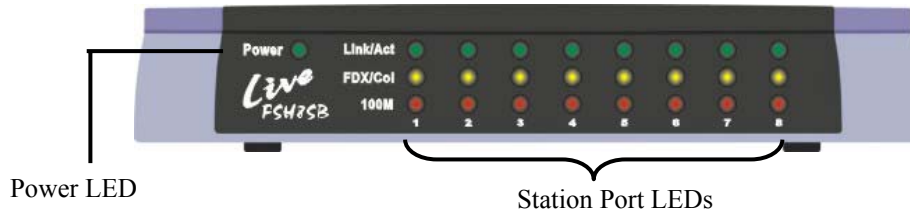

Fig. 2-2 Front Panel

The Rear Panel

The rear panel is where you can locate the DC power jack, the 8 10/100Mbps station ports. For the technical specifications of the ports, please refer to *Appendix A, Product Specifications* for detailed information.

Station Ports (Port #1 to #8)

Live-FSH8SB Fast Ethernet Switch is equipped with 8 10/100Mbps auto-sensing and auto-negotiating ports. You can use these ports to connect to end stations, servers or other networking devices.

DC Power Jack

The DC Power Jack is where you should connect the DC power adapter chord.

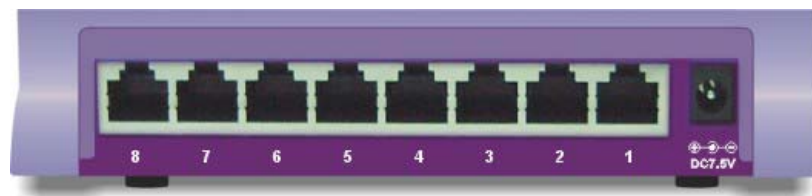

Fig. 2-3 Rear Panel

Power Connector

3 Installation of the Switch

Quick Installation

Live-FSH8SB Fast Ethernet Switch is fully compliant with 10/100BASE-TX Fast Ethernet standards.

2 Steps to Quick Installation

Step 1. Power on the Switch.

Step 2. Connect network devices to the Switch: connect either workstation, server, switch, bridge or router to the station port (10/100BASE-TX), using 100 ohm unshielded twisted pair (category 5 UTP) or shielded twisted-pair (STP) cable.

Desktop Installation

Live-FSH8SB Fast Ethernet Switch has four rubber pads attached on each corner of its underside. These pads serve as cushionings against vibration and prevent the switch from sliding off its position. They also allow adequate ventilation space when you place the switch on top of another device.



Fig. 3-1 Desktop installation

Installation on Wall

Live-FSH8SB Fast Ethernet Switch can be mounted on a wall with wall anchors and screws.

To mount the Switch on wall, please follow the steps below:

- Drill two holes, the distance between both of which should be 4 cm (such as the illustration below).
- Insert wall anchors into these two holes.
- Drive the screws into the top of the wall anchors.
- Mount **Live-FSH8SB** on the screws.

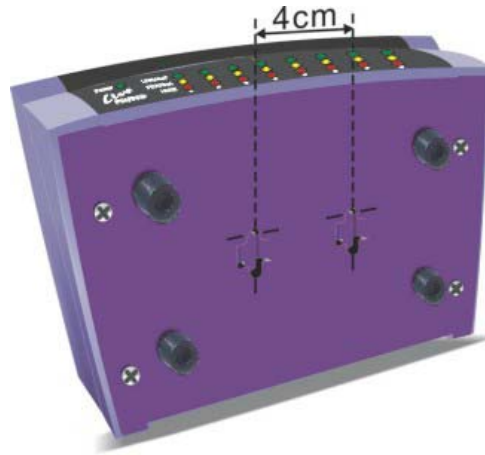

Fig. 3-2 Bottom View of the Switch (showing mounting holes)

Cabling Requirements

Live-FSH8SB Fast Ethernet Switch is primarily designed as a central switching device to provide 10/100Mbps bandwidth to your Ethernet/Fast Ethernet LAN.

Cable requirement for 100BASE-TX Port

Those 8 RJ-45 station ports (MDI-X) all require Cat. 5 twisted-pair UTP/STP cable for connection. When configuring within the 10/100BASE-TX cabling architecture, the cable distance should be within 100m.

The following table summarizes the cable requirement for 10/100BASE-TX connection:

10BASE-T	100 ohm Category 3, 4, 5 UTP/STP cable
100BASE-TX	100 ohm Category 5 UTP/STP cable

Straight-through cabling

Under most conditions, the 8 station ports on the Switch accept normal, straight-through cables, i.e., standard UTP/STP cables, which are the only ones that can be used with a RJ-45 connector

3 Installation of the Switch

interface.

Normally, 10BASE-T networks require a straight-through Cat. 3, 4, 5 UTP/STP cabling system. The cabling system could be found in most existing Ethernet network installations.

100/100BASE-TX networks require Cat. 5 UTP/STP cabling system. The pin assignments for a straight-through cable are shown in Figure 3-5 and 3-6.

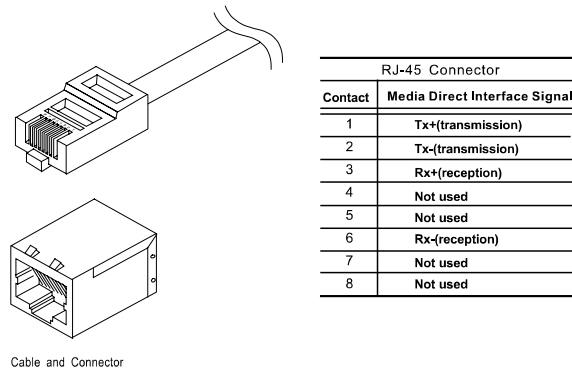

Fig. 3-3 10/100BASE-TX pin assignments for RJ-45 connector

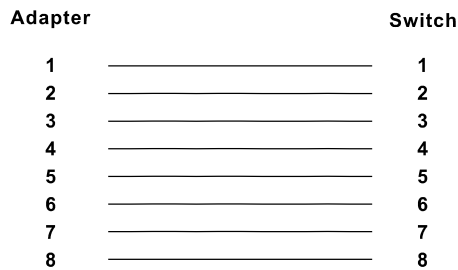

Fig. 3-4 Pin assignments for straight-through cabling

Note:

While connecting Live-FSH8SB to other hub/switch, you don't have to use a crossover cable for connection, since Live-FSH8SB performs auto-crossing over by its Auto-MDI, Auto-MDI-X function. Simply use the straight-through cable for all types of 100BASE-TX connections, either to a PC or to a networking device such as other hub or switch.

The table below describes when to use straight-through or crossover cable:

Connection Specification	Station Port 10BASE-T/100BASE-T
Interface	RJ-45
Cable to Use	
<i>To an end station</i>	Straight-through twisted-pair cable
<i>To a hub/switch</i>	Straight-through twisted-pair cable
Maximum Distance	100 meters

Table 3-1 Cabling type for 10BASE-T/100BASE-TX

Connecting to Power

Live-FSH8SB is accompanied with an external power adapter unit, which is specifically designed for the line voltage and the type of AC outlet used in your location. This power adapter provides the voltage, amperage, and polarity required by the Switch ($7.5V_{DC}@1.5A$, inside positive, outside negative) and is outfitted with the correct type of barrel connector for the DC power jack on the rear panel.

After verifying that the DC power adapter cord is suitable for use, just plug the male end of the DC power adapter into a power outlet on the wall; and plug the barrel connector of the power adapter into DC power jack on the Switch. Once you have correctly plugged in the power, the Switch is activated.

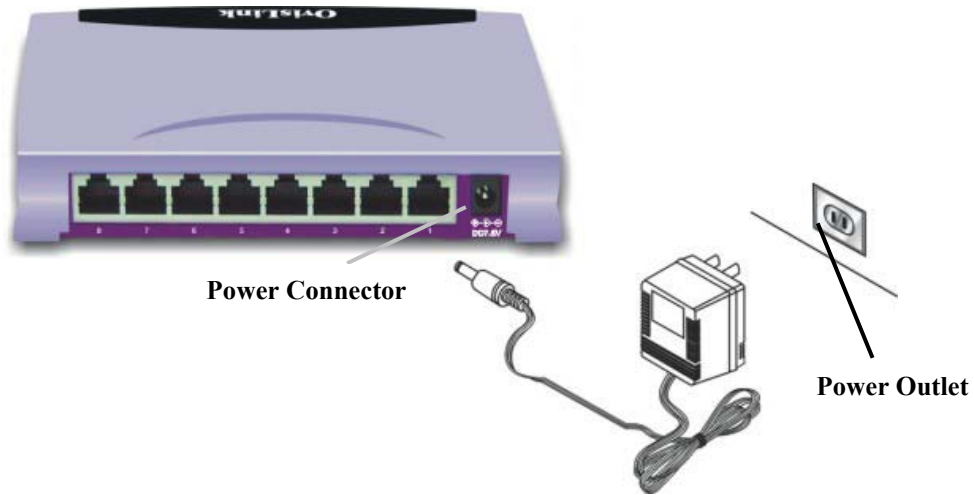

Fig 3-5 Connecting the Switch to power outlet

4 Expanding Your Network

Live-FSH8SB Fast Ethernet Switch is primarily designed as a central switching device to manage your workgroup/departmental traffic within Ethernet/Fast Ethernet.

Its built-in VLAN function offers instant connection without further administration efforts. Furthermore, its secure VLAN feature offers security for virtual workgroups. With your existing Ethernet/Fast Ethernet infrastructure, you can very easily connect, expand or migrate to virtual workgroup computing in an Ethernet/Fast Ethernet environment.

The following sections will introduce to you the basics of network connectivity in virtual workgroup computing within Ethernet/Fast Ethernet environment as well as VLAN and priority configuration.

Connectivity Rules

10 Mbps Connection (10BASE-T)

Ethernet connection should be configured according to the following connectivity rules:

- The maximum length for UTP cables must not exceed 100 meters from end station to a shared-access 10BASE-T hub.
- Between any two end stations in a collision domain, there may be up to five cable segments and four intermediate repeaters at most.
- If there is a path between any two end-stations containing five segments and four repeaters, then at least two of the cable segments must be point-to-point link segments (e.g. 10BASE-T or 10BASE-5), while the remaining segments may be of mixed segments (e.g.: 10BASE-2 or 10BASE-5).

Twisted-pair 100Mbps Connection (100BASE-TX)

Copper-wired Fast Ethernet connection should be configured according to the following connectivity rules:

- The maximum length for STP/UTP cable is 100 meters from end station and a shared-access 100BASE-TX hub.
- The maximum cable length is 100 meters between end station and switch/repeater; and 100 meters between switch and switch/repeater, thus making possible a maximum distance of 300 meters between two end stations.

Connecting to another Switch/Hub

Straight-through Cable Connection for Switch-to-Switch/hub Connection

Use a straight-through cable for the connection made through the station port of **Live-FSH8SB** to any station port of the other switch/hub. Since **Live-FSH8SB** Switch is capable of *auto-crossing over* by its Auto-MDI and Auto-MDI-X function, you don't have to use a crossover cable such as is usually required for this kind of switch-to-switch/hub connection with other switch.



Fig. 4-1 Uplink to another Switch/Hub using straight-through cable

Summary on Connectivity:

- When connecting a PC/hub/switch or any other networking device to the 10/100BASE-TX station port of the **Live-FSH8R**, use a straight-through UTP cable. No crossover cable is required for **Live-FSH8R**. The 10/100BASE-TX cabling distance is 100 meters maximum.

Transmission Modes

Station Ports (10/100BASE-TX Transmission)

All 10/100Mbps station ports of **Live-FSH8SB** Fast Ethernet Switch utilize auto-negotiation to determine the transmission mode for any new connection. This means, if auto-negotiation is supported on both ends of the connection, the Switch is initiated to negotiate for one of the following transmission modes:

- 200Mbps/FDX
- 100Mbps/HDX
- 20Mbps/FDX
- 10Mbps/HDX

LAN Micro segmentation through Switching Technology

Live-FSH8SB Fast Ethernet Switch can effectively segment your network, significantly increasing both bandwidth and throughput. Any port on the Switch can either be attached to a hub (i.e., shared collision domain) or serve as a dedicated link to a single network device (e.g., a workstation). When a port on the Switch is connected to an Ethernet hub (i.e., a 10 or 100 Mbps repeater), the bandwidth provided by that port is shared by all the devices connected to the attached hub. However, when a port is connected to an end node or to a device that breaks up the collision domain, e.g., another Switch, bridge or router, the attached device will have access to the full bandwidth provided by that port.

Micro segmentation of an existing LAN can improve network latency and increase overall performance.

Live-FSH8SB Fast Ethernet Switch uses Store-and-Forward switching to control network traffic, thus ensuring data integrity under heavy load.

5 LED Indicators

Before connecting any network device to **Live-FSH8SB** Fast Ethernet Switch, you should take a few minutes to look over this chapter and get familiar with the front panel LED indicators of your Switch. The front-panel LED indicators of **Live-FSH8SB** comprise 2 sets of LEDs: System Status LEDs and Station Port LEDs. Each set of LEDs gives specific information concerning the system status or the station port status:

Comprehensive LEDs

System LED

Power LED indicates the system power Status.

Station Port LEDs

Station Port LEDs show the port status of each of its eight 10/100 Mbps station ports. There are Link/Act, FDX/Col LED, and 100M for each port.

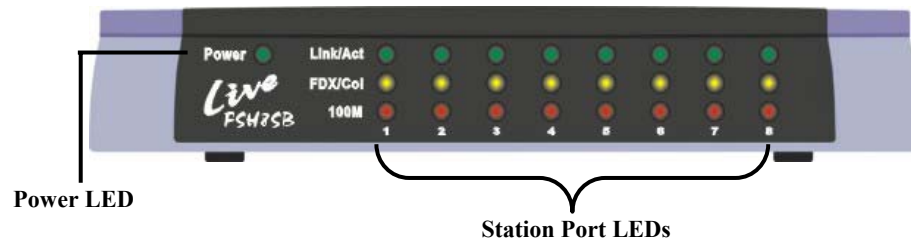

Fig. 5-1 Front-panel LED indicators

The specific function of each LED will be described in full details in the following sections:

Power LED

Power LED will give a solid green light when you turn on the Switch, and will be off when the Switch being turned off. You can simply check the Power LED to see if the Switch is being activated. Before turning on the Switch, please verify that the power cord has been properly connected to the Switch and the power outlet on the wall.

Station Port LEDs

Link/Act LED

Link/Act LED giving a solid green light indicates that a data link has been established between the corresponding port and the device. If no connection is made, it will be off. While the port is transmitting or receiving data, you will see a blinking green light.

FDX/Col LED

FDX/Col LED shows the transmission mode of the connection. When in full-duplex transmission mode, FDX LED gives forth a solid yellow light. When in half-duplex mode, it will be off. While collisions happen in half-duplex mode, the FDX/Col will be blinking.

100M

100M LED giving a solid red light indicates that a 100Mbps data link has been established between the corresponding port and the device. If no 100Mbps connection is made, it will be off.

Table 5-1 Station Port LEDs

LED indicator	Color	Status	Meaning
<i>System LEDs</i>			
Power LED	● Green	ON OFF	Power ON Power OFF
<i>Station Port LEDs</i>			
Link/Act	● Green	ON Blinking OFF	Connection is made Transmitting/Receiving No connection is made
FDX/Col	● Yellow	ON OFF Blinking	Full Duplex Half Duplex Collisions (in half duplex)
100M	● RED	ON OFF	100 Mbps Connection 10 Mbps Connection

Appendix A Product Specifications

- **Standard Compliance**
 - IEEE 802.3 10BASE-T Ethernet
 - IEEE 802.3u 100BASE-TX Fast Ethernet
 - ANSI/IEEE Std 802.3 NWay auto-negotiation

- **Topology** Star

- **Port Configuration**
 - 8 × 10/100 BASE-TX Port

- **Data Rate**
 - *10BASE-T Ethernet*
 - 10 Megabits/sec (half-duplex)
 - 20 Megabits/sec (full-duplex)
 - *100BASE-TX Fast Ethernet*
 - 100 Megabits/sec (half-duplex)
 - 200 Megabits/sec (full-duplex)

- **Transmission method** Store and Forward

- **Full Duplex** Auto-negotiation

- **Active Flow Control**
 - IEEE 802.3x compliant flow control for full duplex
 - Back Pressure for half duplex

- **Filtering Address Table** 1K

- **RAM Buffer** 768 KBytes

- **MAC Address Learning** Automatic update

- **Cabling Type**
 - 10BASE-T: 4-pair 100 ohm Category 3,4,5 UTP (100 m) cable
 - 100BASE-TX: 4-pair 100 ohm Category 5 UTP/STP (100 m) cable

- **LED layout**
 - *System LEDs*
 - Power LED
 - *Station port LEDs for port 1 ~ 8*
 - Link/Act LEDs
 - FDX/Col LEDs
 - 100M LEDs

- **Dimensions** 169*118*29 m/m

Appendix A Production Specifications

- **Net Weight** 600g
- **Power Input** External Power Supply with +7.5v/1A output
120/220V_{AC},50~60 Hz TO DC7.5V/1A
- **Power Consumption** 3.5 Watts max, @ 7.5V DC
- **Operating Temperature** -32 ~ 122 °F / 0 ~ 50 °C
- **Storage Temperature** - 68 ~ 149°F / -20 ~ 65 °C
- **Humidity** < 95% (non-condensing)
- **Safety / EMI Certificates** UL, TUV, VDE, FCC Class A, CE

Appendix B Troubleshooting

This appendix contains specific information to help you identify and solve problems. If your switch does not function properly, please make sure it is set up according to the instructions on the manual.

If you suspect your switch is not connected correctly to your network, check the following points before you contact your local dealer for support.

- Make sure the Power is ON (Check the Power LED).
- Make sure the cable is connected properly on both ends.
- Make sure that the maximum cable length between switch and end node does not exceed 100 meters (for 10/100BASE-TX connection).
- Make sure that the maximum switch-to-hub/switch cable distance does not exceed 100 meters (for 10/100BASE-TX connection).
- Verify that the cabling type used is correct.
- Check the corresponding Link/Act, FDX/Col, 100M for signs of faulty connection. Check the status of the cable attachment. If the problem persists, try a different cable.
- Try another port on the Switch.
- Turn off power supply to the Switch. After a while, turn it on again to see if it resumes to its normal function.
- If you find out where the problem is but cannot solve it by yourself, or you simply cannot locate what is at fault, please contact your local dealer for technical support.

